

**CORBY**  
OF WINDSOR



**DESIGNED FOR HOTELS**

# RELAX, IT'S COVERED



**ELECTRICAL  
GUARANTEE**



Terms and Conditions Apply: Up to 4 Year Electrical Guarantee applies to all mains operated electrical items only. This covers failure due to electrical defects and does not cover wear and tear due to excessive use. The Electrical Guarantee is applied automatically at purchase, no sign up required. For the full list of Terms and Conditions please visit [www.corbyofwindsor.com](http://www.corbyofwindsor.com)

## CONTENTS

**03**

### Introduction

A brief overview of who we are and what we are about.

**05**

### Our Story

Our story from where we started and a timeline of our company milestones.

**07**

### A Culture of Excellence

A section all about the values of our team & the excellent global support they offer.

**09**

### What We Do

A brief overview of our key design principles and what we do here at Corby of Windsor.

**15**

### Essentials by Corby

Practical and affordable products for the hotel guest room.

**17**

### Ironing

Explore our garment care collection; safe, durable and timeless by design.

**29**

### Kettles, Espresso Machine & Trays

Relax & enjoy our latest hospitality range, where functionality meets elegance.

**49**

### Hair Dryers

Our hair dryer collection offers high end luxury alongside eco focused design.

**59**

### Minibars

Explore our refreshing minibar collection; designed to fit a variety of spaces.

**69**

### Safes

Discover a safer guest experience with our hotel safes collection.

**75**

### Bedroom Items

Our bedroom items are the perfect addition to enhance your guests stay.

**89**

### Bathroom Items

Unwind with our range of stylish, easy to clean bathroom items.

#### KEY OF SYMBOLS

- New Product
- Eco Friendly
- British Design
- 4 Year Guarantee
- USA Approved
- 2 Year Guarantee
- Accessibility Friendly
- Made of BUSA bamboo

# CORBY OF WINDSOR

*Specialists in electricals for the hotel guest room*

We at Corby of Windsor specialise in the design, manufacture and supply of hotel guest room products. With decades of experience in producing electrical appliances, we have the knowledge necessary to ensure our products are not only produced to a consistent standard but they are also appropriately accredited and certified for the markets they serve. We export to over 60 countries worldwide and are specified in many branded hotel chains.



# CORBY OF WINDSOR

Established in 1930

Incorporated originally by Mr John Corby in Windsor in 1930, Corby of Windsor is famous for its' garment care products, particularly the trouser press. Over the years, Corby has expanded into the manufacture of electrical products within the garment care category becoming a household name in the 1980s as its' products are procured by hotels around the world.



## In 2009

Corby of Windsor was acquired by Fired Up Corporation

Fired Up Corporation Ltd is a global manufacturer and direct sourcing expert, with multiple factories and distribution centres around the world. Its expertise is within electrical appliances, operating under 10 product brands and producing over 500,000 products per year.



OUR STORY

- 1930** Trouser Press manufacturing begins in Windsor, UK.
- 1950** Corby invents the worlds first electric trouser press.
- 1980** Over 100,000 electric presses are sold in one year.
- 2000** Corby of Windsor expand the range of hotel electrical products to include irons and ironing centres, kettles and ancillary products.
- 2009** Fired Up Corporation purchase Corby of Windsor and utilising our extensive design and production facilities expands the range further, to include minibars, hairdryers, safes and scales.
- 2010** A broad range of welcome trays are introduced including the world's first ever drip tray option.
- 2011** Global expansion continues and distributors are appointed in the Middle East and Asia.
- 2012** Another product first, the 180° iron holding brackets are introduced to our ironing centres.
- 2015** Alliances with some of the worlds biggest brands ensure we have a global presence and Corby products are now exported to over 60 countries worldwide.
- 2018** Corby of Windsor collaborate with Nescafé on the Buckingham Compact Welcome Tray.
- 2021** Canterbury collection is introduced – Over 96 Welcome tray combinations.
- 2022** Corby of Windsor introduces the worlds highest rated glass door minibar with the Eton E.
- 2023** New distribution centre opens in Czechia to service customers in Europe.
- 2024** Corby of Windsor introduces a range of eco-friendly solutions including the Skye high speed hair dryer as well as the Thornton and Newport recycling collection.
- 2025** Introduced the innovative Darlington Garment Mat as well as the new Essentials by Corby range.

OUR STORY 06

The Trouser Press invented by Mr John Corby in Windsor in 1930.

# A CULTURE OF EXCELLENCE

For almost 100 years, Corby of Windsor has been devoted to delivering exceptional service for customers worldwide.

As a leading manufacturing brand in the hotel and hospitality industry, our success depends on the quality of our work, attitude, expertise, innovation, and how we treat people. Our dedicated business development and account management team are here to serve you.

In everything we do, our team upholds the following principles;

 COMMITMENT

Our brand represents our reputation. We are devoted to maintaining the supply of world-class products and services to our customers worldwide. We strive to build sustainable partnerships that continue to reflect and strengthen the integrity of the Corby of Windsor name.

 PASSION

We design, source and manufacture products that are specifically created for the hotel guest room. We rely on customers to help us find the next opportunity, which keeps every relationship fresh and every new project exciting.

 EMPATHY

We are receptive to the needs of our customers. Our customers are our eyes, ears and voice in the market and their needs guide our focus.

 EXPERTISE

We have vast experience in knowing when, where and how to add value for our customers. Our multicultural, highly-skilled team are trained in design, production and international trade and global supply chain operations to ensure we meet and exceed our customers requirements.

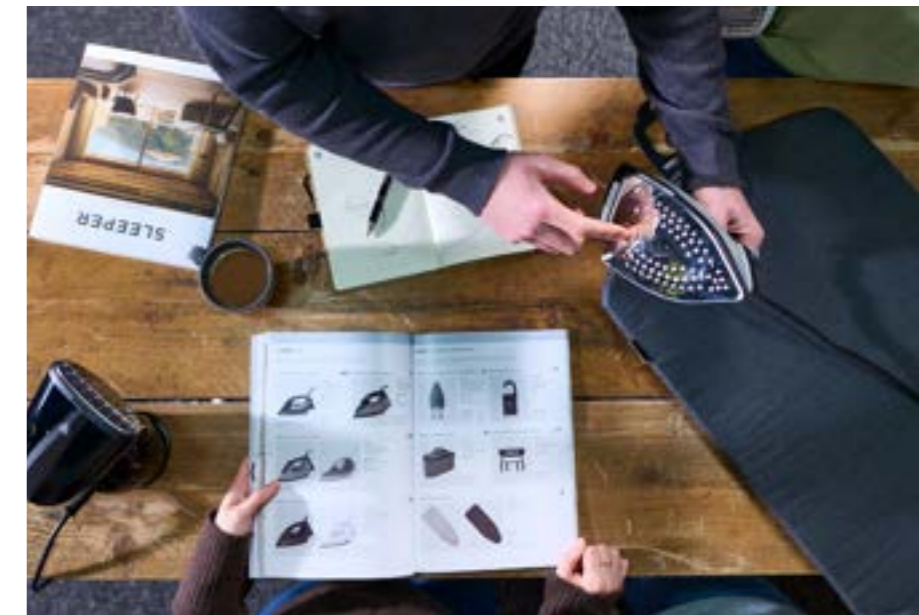

## 🇬🇧 DESIGNED FOR HOTELS

Our UK team of designers have worked with architects, interior designers and furniture manufacturers to create an attractive and versatile range, designed for hotels. We are selective in the materials we use and ensure each product is tested with the hotel and guest in mind.

Over the years, we have influenced the industry with our creative thinking and unique safety solutions to set the standard in guest room electricals, and work continuously to evolve our range.

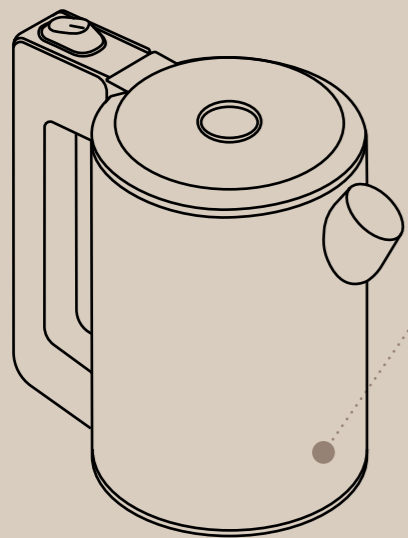

CANTERBURY 0.6L KETTLE  
Hotel specific 0.6L kettle design

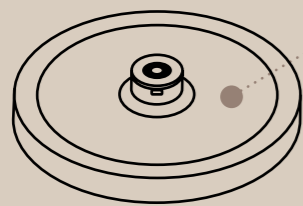

DUAL KETTLE BASE (0.6L & 1L)  
Innovative interchangeable kettle base

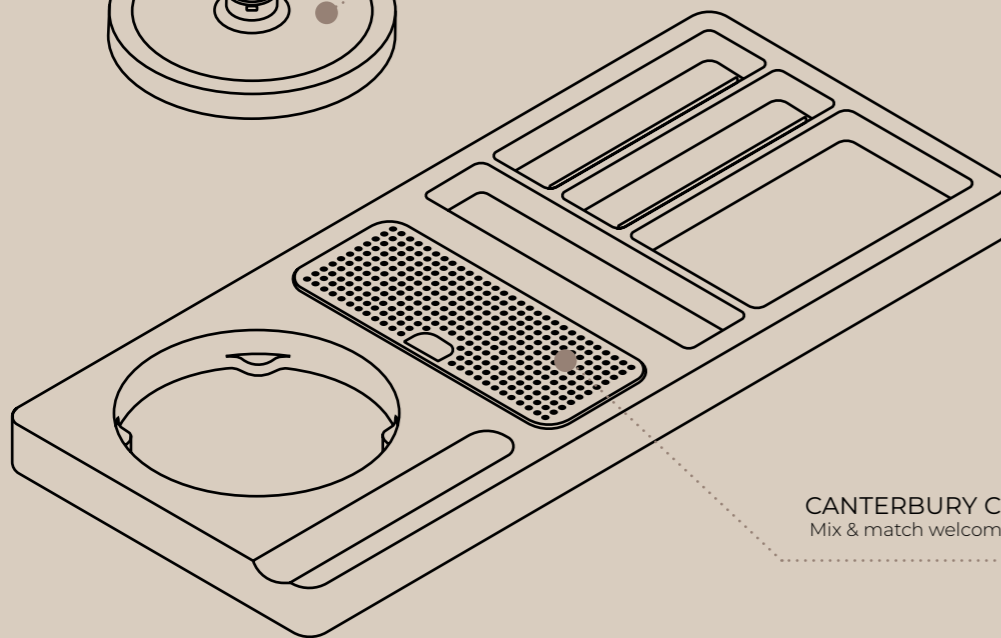

CANTERBURY CLASSIC WELCOME TRAY  
Mix & match welcome tray design for 0.6L & 1L kettles

STAINLESS STEEL DRIP TRAY  
Innovative design introduced in 2009



## 4 ENGINEERED TO LAST

We look at all aspects of construction, materials and 'life testing' to ensure we have the best products for the market. We understand the needs of the customer, so we implement strict measures throughout the manufacturing process in our factories to ensure our products meet the high standards we set ourselves.

*Our Guarantee on electrical products supports this philosophy.*



WHAT WE DO  
11

 **GLOBAL SUPPLY & SUPPORT**

We have high levels of stockholding and logistics capabilities in UK, EU, USA and China with direct shipping options and stockholding distributors in key growth territories.

We have significant competence in international certification and accreditation, with considerable experience in export and distribution of electrical products worldwide.



WHAT WE DO  
12

 **HOTEL SPECIFIED**

Our specialised range of hotel electricals & accessories is ever-evolving alongside styles & trends we see around the world, which is why we are confident we can accommodate any guest room environment.

This is why our products are specified for many of the world's largest hotel chains, making the introduction to our pre-approved product range a simpler and speedier process.



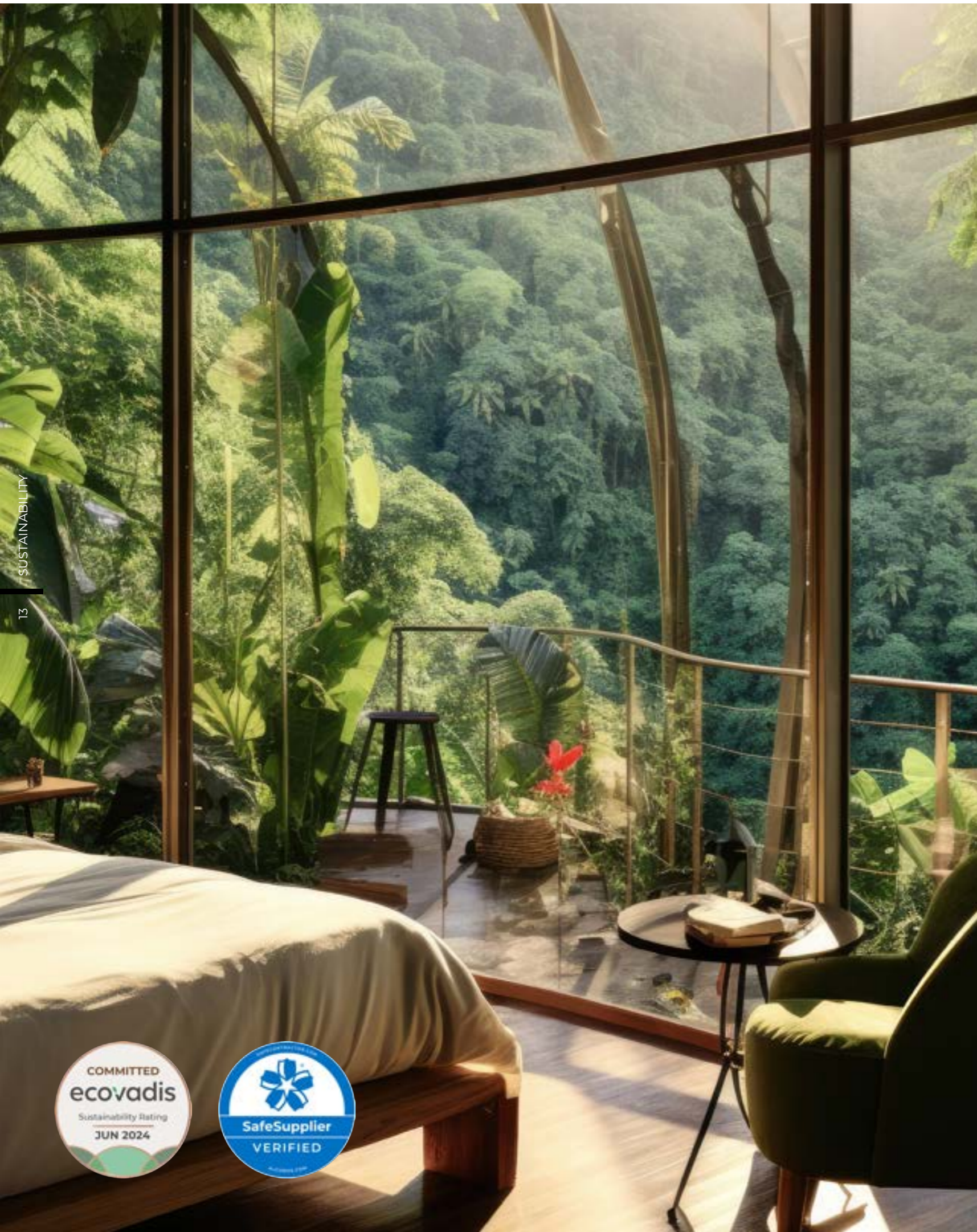

# SUSTAINABILITY FOCUSED

Corby of Windsor recognises the value in identifying and minimising the environmental impact of our products and operations. We remain committed to the continuous improvement of our sustainability performance to protect the planet for current and future generations.

As a designer and producer, we look at all aspects of the product life cycle, from the materials we use to how our products are manufactured. We continue to challenge conventional production methods to better suit the customer & the environment.

## In recent years we have:



Improved the assembly process to be more user friendly for local repair. We have also increased the availability of spare parts across the range.



Prevented 82,000 toxic chrome plated items entering the market by finding eco-friendly finishing methods.  
\*Data taken between 31/8/23 - 1/9/24



Joined the World's most trusted sustainability business rating Ecovadis. We are also verified with Alcumus SafeSupplier.



Introduced the Skye hair dryer which dries hair twice as fast whilst using 58% less energy\*  
\*Based on testing against the Bedford 2000W hair dryer.



Expanded our range of recycling options to offer up to 28 guestroom waste solutions.



Introduced the BUSA range of trays and accessories, made from the worlds most sustainable material, bamboo.

We have ambitious plans to become a net zero company by 2036 and we are committed to drive change throughout the business and help reduce the impact to the environment within the hospitality industry.



# essentials

by CORBY

Essentials by Corby is a streamlined range of guest room products designed with affordability in mind. As a sub-brand of Corby, it reflects our commitment to safety, reliability, and value while delivering practical, cost-effective solutions without compromising on quality.

Essentials products undergo the same rigorous testing and quality assurance processes that define the Corby brand and are readily available through our international distribution network.

Typically unbranded, Essentials by Corby products are designed with a focus on functionality and simplicity, in contrast to the innovation-led approach of the main Corby range. Each item is supported by a two-year electrical guarantee, ensuring dependable performance for everyday guest room requirements.

## Essentials by Corby: Practical, Affordable Guest Room Solutions



### 2-year guarantee on electricals

Following the same in-house test procedures throughout development, Essentials products are functional and reliable. That's why we offer a 2-year guarantee on electricals.



### Affordable

We work with our OEM (Own Equipment Manufacturer) partners to offer a range of products where investment in tooling and new certification is minimised, resulting in affordable solutions for the hotel guest room.



### Minimal branding

Essentials products are typically unbranded, allowing hotels to maintain a consistent and uncompromised brand identity throughout the guest room. The same minimalist approach extends to the packaging, which features plain boxes with only the necessary information required for export and legal compliance.



### Supplied & supported by Corby

As a sub-brand of Corby, Essentials offers the same exceptional service and support delivered by our international team. Products are stocked and distributed through the same trusted global distribution centres, ensuring reliable availability and consistency.





# SWING INTO ACTION

Originally invented by Corby of Windsor, the 180° iron holder has set the standard in guest room ironing. We have evolved all of our ironing centres to be effortless to use as well as space-saving. We have also revolutionised the manufacturing process for this, reducing the total number of parts required and completely removing the need for chrome plating.



## CORBY IRONING COLLECTION

As experts in garment care for over 90 years, our specialised range offers attractive solutions that are engineered to be functional, durable & safe. From all-in-one ironing centres to compact ironing boards, we are confident we have the perfect combination to suit your guest room.



### 3-way cut-off

All Corby irons are programmed with a 3-way cut-off, designed to keep both guests and hoteliers safe if an iron is left unattended.

## SAFE & SECURE

All Corby irons are programmed to have a 3-way cut-off feature, so hoteliers have peace of mind if an iron is left unattended. The iron will simply switch off after 30 seconds if left horizontally or 8 minutes if left vertically.

Our all-in-one ironing centres are a great example of form and function. Everything you need is attached to the centre, making ironing safe and convenient. Each centre is fitted with a cable tidy system and an anti-theft device to help prevent irons from being stolen.



### Anti-theft

All Corby of Windsor ironing centres are fitted with an anti-theft device to help prevent irons being stolen.

# TAILOR MADE SOLUTIONS

Corby of Windsor has been manufacturing quality garment care products since 1930. Our specialised range of hotel electricals & accessories is ever-evolving alongside styles & trends we see around the world, which is why we are confident we can accommodate any guest room environment.



Table Top



Darlington



Cambridge



Berkshire



Oxford



Classic

## CORBY OXFORD IRONING COLLECTION

Specifically designed for hotels, the Oxford range offers full-size ironing solutions featuring a sleek, surfboard-style board design. With quick-release handles on both sides, the Oxford is user-friendly and convenient for both left- and right-handed guests.

### OXFORD IRONING CENTRE / Steam or Dry



**Features:**

- Compatible with Sherwood 1100W Steam Iron
- Integrated hanger & cable tidy
- Easy open mechanism
- Anti-theft security box
- 3-way auto cut-off system

**Specification:**

Light Grey / Dark Grey  
5.15kg - 5.90kg  
2.5m - 3m cable length  
\*Iron & Iron holder supplied separately

**Dimensions:**

(Board Open)	(Board Closed)
Height - 590 - 840mm	Height - 1270mm
Width - 1015mm	Width - 360mm
Depth - 340mm	Depth - 265mm

## CORBY BERKSHIRE IRONING COLLECTION

Specifically designed for hotels with limited storage, the Berkshire range offers a compact, space-saving solution that combines practicality and convenience, ensuring guests enjoy seamless usability without compromising on functionality.

### BERKSHIRE IRONING CENTRE / Steam or Dry

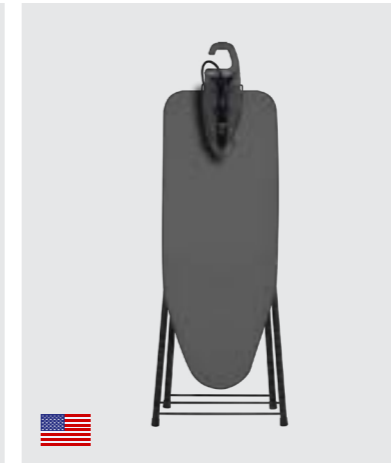

**Features:**

- Compatible with Sherwood 1100W Steam Iron
- Integrated hanger & cable tidy
- Deck chair mechanism
- Anti-theft security box
- 3-way auto cut-off system

**Specification:**

Light Grey / Dark Grey  
4.65kg - 4.80kg  
2.5m - 3m cable length  
\*Iron & Iron holder supplied separately

**Dimensions:**

(Board Open)	(Board Closed)
Height - 755mm	Height - 1135mm
Width - 895mm	Width - 400mm
Depth - 340mm	Depth - 210mm

### OXFORD IRONING BOARD WITH HANGER



**Features:**

- Durable powder coated legs and frame
- Easy open mechanism
- Lightweight design
- 7 height positions
- Burn-proof aluminised cover

**Specification:**

Light Grey / Dark Grey  
3.70kg  
\*Ironing Board Hanger supplied separately

**Dimensions:**

(Board Open)	(Board Closed)
Height - 590 - 840mm	Height - 1220mm
Width - 1100mm	Width - 360mm
Depth - 340mm	Depth - 70mm

### BERKSHIRE IRONING BOARD WITH HANGER

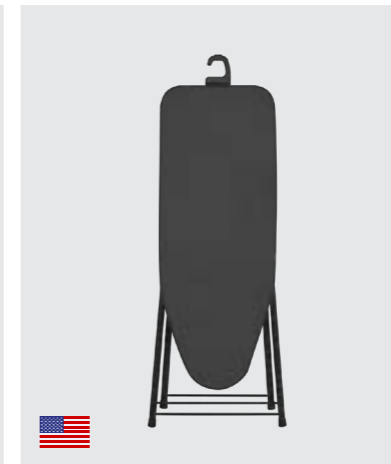

**Features:**

- Durable powder coated legs and frame
- Deck chair mechanism
- Lightweight design
- Burn-proof aluminised cover

**Specification:**

Light Grey / Dark Grey  
3.20kg  
\*Ironing Board Hanger supplied separately

**Dimensions:**

(Board Open)	(Board Closed)
Height - 755mm	Height - 1115mm
Width - 895mm	Width - 400mm
Depth - 340mm	Depth - 50mm

### OXFORD IRONING BOARD

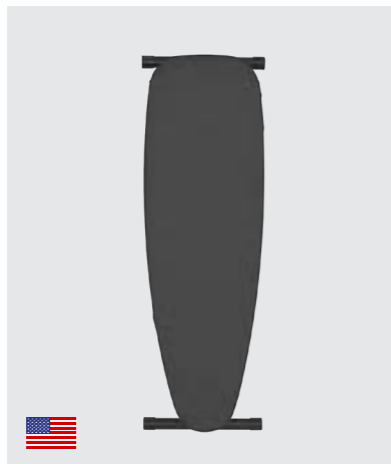

**Features:**

- Durable powder coated legs and frame
- Easy open mechanism
- Lightweight design
- 7 height positions
- Burn-proof aluminised cover

**Specification:**

Light Grey / Dark Grey  
3.50kg

**Dimensions:**

(Board Open)	(Board Closed)
Height - 590 - 840mm	Height - 1125mm
Width - 1100mm	Width - 360mm
Depth - 340mm	Depth - 70mm

### BERKSHIRE IRONING BOARD

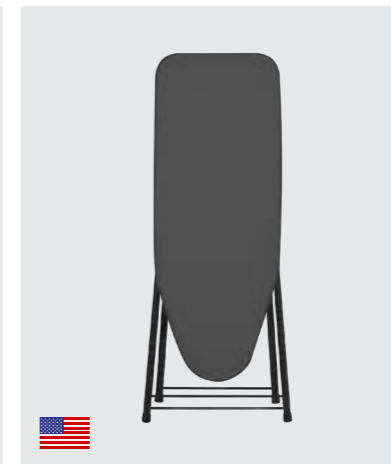

**Features:**

- Durable powder coated legs and frame
- Deck chair mechanism
- Lightweight design
- Burn-proof aluminised cover

**Specification:**

Light Grey / Dark Grey  
3kg

**Dimensions:**

(Board Open)	(Board Closed)
Height - 755mm	Height - 1000mm
Width - 895mm	Width - 400mm
Depth - 340mm	Depth - 50mm

## CORBY SUTTON TABLE TOP IRONING COLLECTION

When space is limited, the Sutton Table Top range offers a full ironing solution that's effortless to use. With a fixed-leg design, there's no need for unfolding, just place it on a surface and it's ready to go.

### SUTTON TABLE TOP IRONING CENTRE / *Steam or Dry*



- Features:**
- Compatible with Sherwood 1100W Steam Iron
  - Integrated hanger & cable tidy
  - Compact board size
  - Anti-theft security box
  - Fixed ABS legs
  - 3-way auto cut-off system

**Specification:**  
 Light Grey  
 3.40kg - 4kg  
 2.5m - 3m cable length  
 \*Iron & Iron holder supplied separately

**Dimensions:**  
 Height - 250mm  
 Width - 910mm  
 Depth - 345mm

## CORBY GARMENT MAT & IRONING BOARDS

Designed with hotel guests in mind, Corby offers a versatile range of alternative ironing solutions, including an innovative garment mat, a space-saving wall-mounted option, and other thoughtfully engineered designs to suit a variety of room layouts and guest needs.

### IRONING BOARD (CLASSIC / IB0007)

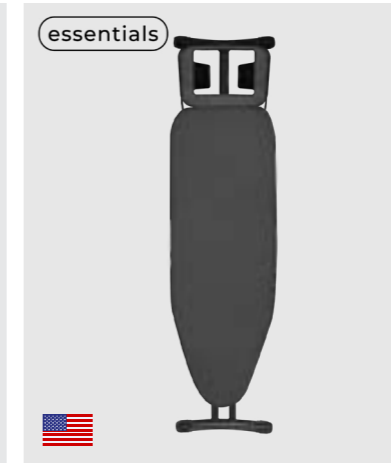

- Features:**
- Durable powder coated legs and frame
  - 7 height positions
  - Easy open mechanism
  - Lightweight design
  - Built-in iron rest
  - Burn-proof aluminised cover

**Specification:**  
 Dark Grey / Light Grey  
 1.50kg

**Dimensions:**

(Board Open)	(Board Closed)
Height - 665 - 835mm	Height - 1240mm
Width - 940mm	Width - 360mm
Depth - 330mm	Depth - 65mm

### SUTTON TABLE TOP IRONING BOARD WITH HANGER

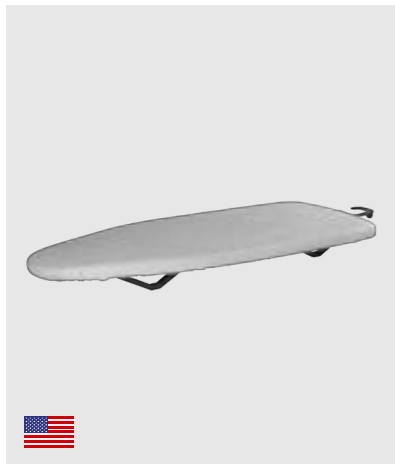

- Features:**
- Durable powder coated legs and frame
  - Fixed ABS legs
  - Lightweight
  - Burn-proof aluminised cover
  - Protective rubber feet

**Specification:**  
 Light Grey  
 1.92kg  
 \*Ironing Board Hanger supplied separately

**Dimensions:**  
 Height - 77mm  
 Width - 875mm  
 Depth - 345mm

### DARLINGTON GARMENT MAT



- Features:**
- Integrated hook & hanger
  - Double sided garment mat
  - Suitable for ironing & steaming
  - Burn-proof aluminised cover
  - Lightweight & slim line design

**Specification:**  
 Dark Grey  
 1.50kg

**Dimensions:**  
 Height - 995mm  
 Width - 420mm  
 Depth - 60mm

### CAMBRIDGE IRONING BOARD / *Wall Mounted*



- Features:**
- Wall mounted
  - Space saving design
  - Easy to open
  - Burn-proof aluminised cover

**Specification:**  
 Dark Grey  
 6kg

**Dimensions:**  
 Height - 805mm  
 Width - 350 mm  
 Depth - 50mm - 733mm

### SUTTON TABLE TOP IRONING BOARD



- Features:**
- Durable powder coated legs and frame
  - Fixed ABS legs
  - Lightweight
  - Burn-proof aluminised cover
  - Protective rubber feet

**Specification:**  
 Light Grey  
 1.72kg

**Dimensions:**  
 Height - 77mm  
 Width - 770mm  
 Depth - 35mm

### TABLE TOP IRONING BOARD (IB0009)

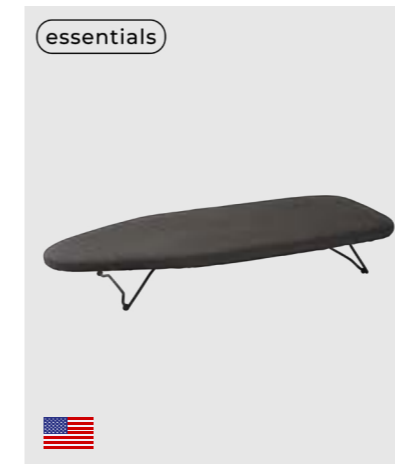

- Features:**
- Slimline design
  - Easy open mechanism
  - Lightweight
  - Burn-proof aluminised cover
  - Protective rubber feet

**Specification:**  
 Dark Grey  
 0.91kg

**Dimensions:**  
 Height - 33mm - 120mm  
 Width - 772mm  
 Depth - 318mm

## CORBY GARMENT STEAMER & IRONS

Corby offers a range of dry and steam irons from 1200W to 2000W, all engineered with a safety-focused auto shut-off system (8 minutes upright / 30 seconds horizontal) for reliable, hassle-free use. For guests on the go, the Stockton Garment Steamer provides a convenient and easy-to-use alternative.

### STOCKTON GARMENT STEAMER

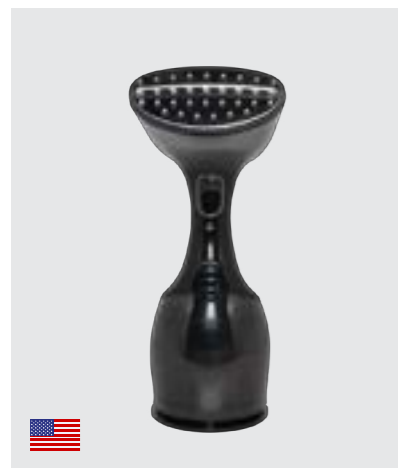

- Features:**
- Non-stick stainless steel plate
  - Continuous steam rate 20-25g
  - Trigger activated - 2x steam settings
  - 270ml detachable water tank
  - Auto cut-off after 1 min

**Specification:**  
 Black  
 1.10kg  
 1200W  
 3m cable length

**Dimensions:**  
 Height - 295mm  
 Width - 115mm  
 Depth - 145mm



### SHERWOOD 2000W STEAM IRON



- Features:**
- Stainless steel soleplate
  - Self cleaning function
  - Adjustable temperature dial
  - Hotel safety iron
  - 3-way auto cut-off

**Specification:**  
 Black & Grey  
 1.20kg  
 2000W  
 330ml water tank  
 3m cable length

**Dimensions:**  
 Height - 160mm  
 Width - 290mm  
 Depth - 117mm

## CORBY IRONING ACCESSORIES

Corby accessories complete the ironing package with a selection of stylish, functional storage solutions designed for guest rooms. Several options include anti-theft features, offering added peace of mind for hoteliers.

### BRIXTON IRON & STEAMER CADDY



- Features:**
- Heat resistant reinforced base
  - Cord tidy storage
  - Carry handle
  - Suitable for hanging on Corby hooked boards
  - Accommodates all Corby irons & the Stockton garment steamer

**Specification:**  
 Dark Grey & Black  
 0.25kg

**Dimensions:**  
 Height - 302mm  
 Width - 302mm  
 Depth - 22mm



### SHERWOOD IRON & IRONING BOARD HOLDER

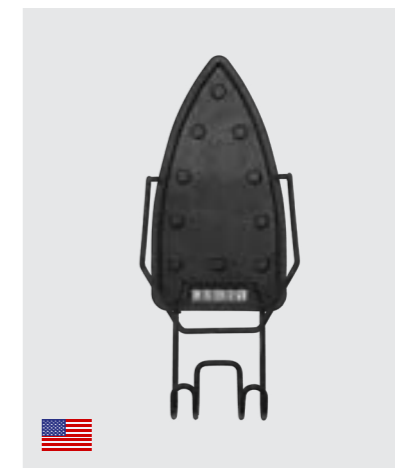

- Features:**
- Wall mounted holder
  - Concealed fixings
  - Rigid & durable construction
  - Heat resistant resting plate
  - Full sole plate protection
  - Accommodates all Corby irons

**Specification:**  
 Black  
 0.30kg - 0.40kg

**Dimensions:**  
 (1200W) (1600W/2000W)  
 Height - 335mm Height - 380mm  
 Width - 130mm Width - 140mm  
 Depth - 110mm Depth - 125mm



### SHERWOOD 1100W STEAM IRON

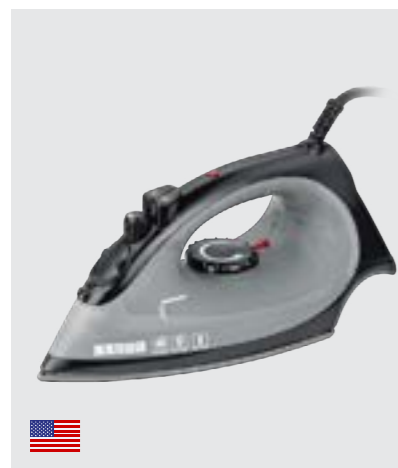

- Features:**
- Stainless steel soleplate
  - Compact & lightweight
  - Adjustable temperature dial
  - Hotel safety iron
  - 3-way auto cut-off

**Specification:**  
 Black & Grey  
 0.75kg  
 1100W  
 145ml water tank  
 2.5m cable length

**Dimensions:**  
 Height - 120mm  
 Width - 250mm  
 Depth - 105mm



### SHERWOOD 1200W DRY IRON



- Features:**
- Non-stick soleplate
  - Compact & lightweight
  - Adjustable temperature dial
  - Hotel safety iron
  - 3-way auto cut-off

**Specification:**  
 Black  
 0.60kg  
 1200W  
 2.5m cable length

**Dimensions:**  
 Height - 120mm  
 Width - 250mm  
 Depth - 105mm

### SHERWOOD IRONING BOARD HOLDER

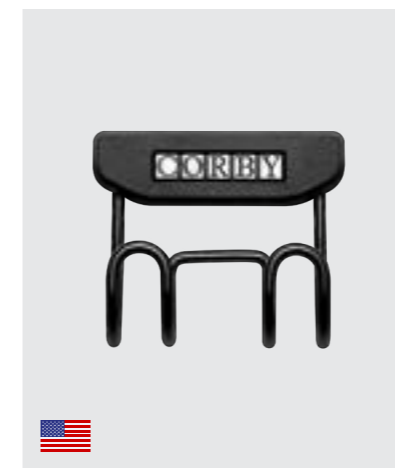

- Features:**
- Wall mounted holder
  - Concealed fixings
  - Rigid & durable construction
  - Accommodates all Corby ironing boards except Sutton

**Specification:**  
 Black  
 0.10kg

**Dimensions:**  
 Height - 90mm  
 Width - 100mm  
 Depth - 45mm



### IRONING BOARD HANGER

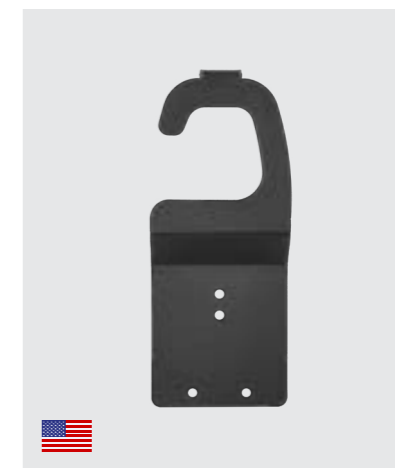

- Features:**
- Easy to fit
  - Compatible with Oxford, Berkshire & Sutton

**Specification:**  
 Black  
 0.20kg

**Dimensions:**  
 Height - 186mm  
 Width - 75mm  
 Depth - 25mm



### 1600W STEAM IRON (Y-879)

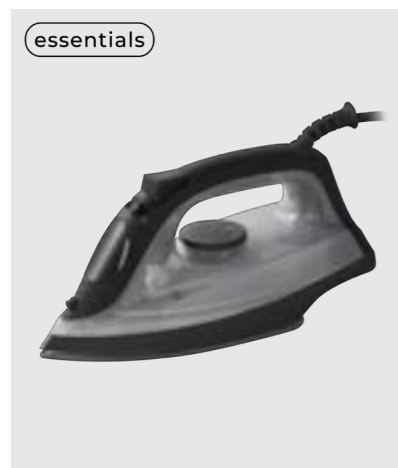

essentials

- Features:**
- Ceramic sole plate
  - Self-cleaning function
  - Adjustable temperature dial
  - Hotel safety iron
  - 3-way auto cut-off

**Specification:**  
 Black & Grey  
 0.90kg  
 1600W  
 180ml water tank  
 2.5m cable length

**Dimensions:**  
 Height - 110mm  
 Width - 250mm  
 Depth - 165mm

### DURHAM HOLDER

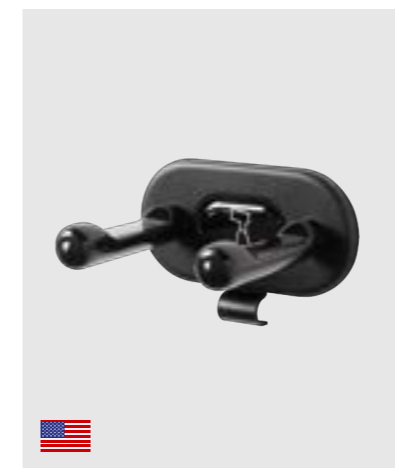

- Features:**
- Wall mounted with optional anti-theft feature
  - Durable steel construction
  - Concealed fixings with product icon
  - Anti-scratch protection
  - Compatible with Stockton Garment Steamer

**Specification:**  
 Black  
 0.29kg

**Dimensions:**  
 Height - 69mm  
 Width - 110mm  
 Depth - 81mm



### IRONING CENTRE HOLDER



- Features:**
- Integrated hook
  - Durable powder coated finish
  - Original 180° rotating design
  - Protective silicone plate
  - Compatible with Oxford, Berkshire & Sutton

**Specification:**  
 Black  
 0.86kg  
 Option A - 1200W Irons  
 Option B - 1600W & 2000W Irons

**Dimensions:**  
 Height - 91mm  
 Width - 120mm - 130mm  
 Depth - 314mm





KETTLES, ESPRESSO MACHINE & TRAYS

## CORBY ESPRESSO MACHINE, KETTLES & TRAYS

Designed for hotels, our eco-friendly kettles & trays are available in a wide range of sizes, finishes and styles. Our welcome trays with their innovative drip tray feature have shaped the industry, providing guests with everything they need to make a relaxing hot drink.

# A WARM WELCOME

A warm drink is a great way to start the day. Feel relaxed and assured that Corby of Windsor will not let you down. With decades of experience in designing and manufacturing electrical products for the hotel industry, we understand what our customers require of us; that's why we offer up to a 4 year guarantee on all electrical products.



KETTLES, ESPRESSO MACHINE & TRAYS

30



### British Designed

Our products are designed by our UK based team of product developers in collaboration with international engineering teams. The team examines all aspects of construction, materials and 'life testing' to ensure we have the best possible offering in terms of value & serviceability for hoteliers.

# RELAX & SWITCH OFF

Corby kettles have been engineered with world-leading Strix Technology. Strix thermal controllers are manufactured to exceed 12,000 cycles of normal operation, so hoteliers & guests will have peace of mind that their kettles will perform.



**Strix Technology**

Corby kettles are engineered with world leading thermal control technology.



**Lift Off Reset**

Corby Kettles are fitted with an additional safety system that only allows the kettle to dry boil once. This feature is designed to keep both guests and hoteliers safe if a kettle is left to dry boil unattended.

## CORBY KETTLES

Engineered with world-leading Strix thermal control technology, our kettles are available in a variety of colours and sizes, with matching welcome trays to complement any room design. Designed specifically for hotel guests, they feature concealed heating elements and 360° swivel bases, making them both easy to use and effortless to clean.

### CANTERBURY 0.6L DOUBLE WALLED KETTLE



- Features:**
- Silicone insulation sleeve
  - Push button lid
  - 360° base
  - Concealed heating element
  - Integrated filter
  - Easy to clean
  - Strix thermal controller

**Specification:**  
 Brushed Steel / Black  
 0.90kg  
 1000W  
 0.8m cable length

**Dimensions:**  
 Height - 158mm  
 Width - 122mm  
 Depth - 206mm

### KENSINGTON 0.6L KETTLE



- Features:**
- Push button lid
  - 360° base
  - Removable filter
  - Strix thermal controller

**Specification:**  
 Brushed Steel & Black  
 0.70kg  
 1000W  
 0.7m cable length

**Dimensions:**  
 Height - 195mm  
 Width - 175mm  
 Depth - 120mm

### 1L KETTLE (BUCKINGHAM / KTL0003)

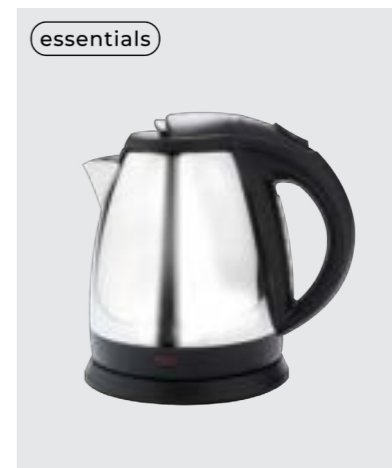

- Features:**
- 360° base
  - Concealed heating element
  - Removable filter
  - Integrated water level window
  - Strix thermal controller

**Specification:**  
 Polished Steel & Black  
 0.80kg  
 1250W - 1500W  
 0.7m cable length

**Dimensions:**  
 Height - 210mm  
 Width - 205mm  
 Depth - 158mm

### CANTERBURY 0.6L KETTLE



- Features:**
- Push button lid
  - 360° base
  - Concealed heating element
  - Integrated filter
  - Easy to clean
  - Strix thermal controller

**Specification:**  
 Brushed Steel / Black  
 0.80kg  
 1000W  
 0.8m cable length

**Dimensions:**  
 Height - 158mm  
 Width - 118mm  
 Depth - 206mm

### 1L KETTLE (LANCASTER / KTL0004)

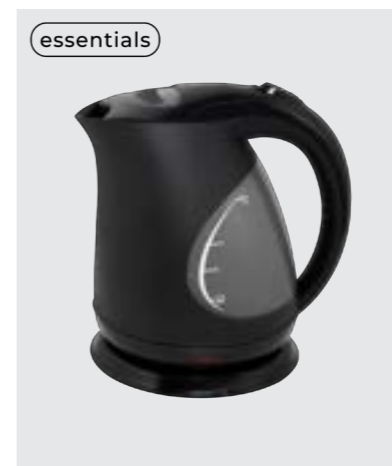
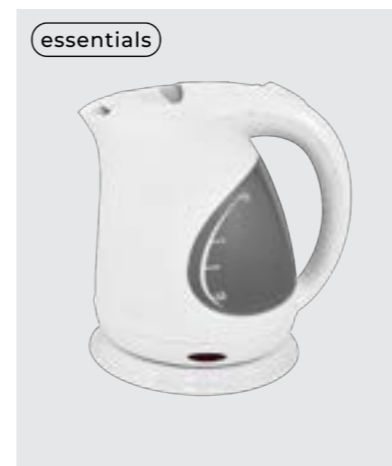

- Features:**
- 360° base
  - Concealed heating element
  - Integrated water level window
  - Removable filter
  - Strix thermal controller
  - Matt & gloss finish

**Specification:**  
 White / Black  
 0.70kg  
 1200W - 1500W  
 0.7m cable length

**Dimensions:**  
 Height - 190mm  
 Width - 180mm  
 Depth - 143mm

### CANTERBURY 1L KETTLE



- Features:**
- Push button lid
  - 360° base
  - Concealed heating element
  - Integrated filter
  - Easy to clean
  - Strix thermal controller

**Specification:**  
 Brushed Steel / Black  
 0.82kg  
 1500W  
 0.8m cable length

**Dimensions:**  
 Height - 188mm  
 Width - 118mm  
 Depth - 206mm

### 0.6L DOUBLE LAYER KETTLE (SD-132)

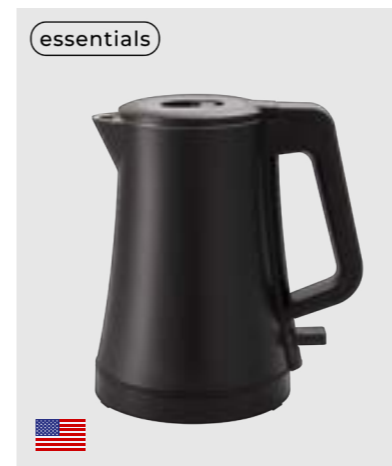

- Features:**
- Cool touch
  - Wide stable base
  - Double layer design
  - 360° base
  - Easy to clean
  - Integrated filter
  - Strix thermal controller

**Specification:**  
 Black  
 0.76kg

**Dimensions:**  
 Height - 213mm  
 Width - 195mm  
 Depth - 143mm



## ESSENTIALS LONG STAY KETTLE & TOASTER DUO

Designed specifically for longer-stay guests, the Hertford & Chelmsford duo combines a larger-capacity kettle with a spacious toaster, providing convenient and practical appliances ideal for families. These durable, easy-to-use options enhance the comfort of extended stays by catering to everyday needs with efficiency and style.



### 1.8L KETTLE (HERTFORD / SD-259)

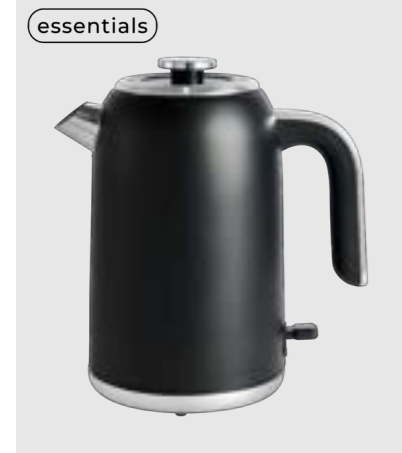

- Features:**
- Removable lid
  - Integrated filter
  - Concealed heating element
  - On/Off LED indicator switch
  - Easy to clean
  - Strix thermal controller

**Specification:**  
 Black  
 1.0kg  
 1800W  
 0.7m cable length

**Dimensions:**  
 Height - 250mm  
 Width - 230mm  
 Depth - 150mm

### 2 SLICE TOASTER (CHELMSFORD / THT-8016A)



- Features:**
- Variable timing controls
  - LED indicators
  - Side out crumb tray
  - Wide slots
  - Anti-jam function

**Specification:**  
 Black  
 1.40kg  
 0.75m cable length

**Dimensions:**  
 Height - 185mm  
 Width - 285mm  
 Depth - 160mm

## CORBY ESPRESSO MACHINE, CUPS & MUGS

For true coffee enthusiasts, the Corby Camden Espresso Machine is equipped with a high-performance Italian pump, ensuring rich, authentic barista-style coffee every time. Its sleek design pairs seamlessly with our carefully curated collection of stylish cups and mugs, enhancing the guest experience. Compact and user-friendly, the Camden is perfect for hotel rooms or lounges, offering guests café-quality coffee at their convenience.

### CAMDEN ESPRESSO MACHINE



- Features:**
- Compatible with 'Nespresso Original' styled pods
  - Compact design
  - Italian pump
  - LED control buttons
  - Used capsule compartment

**Specification:**  
 Black  
 2.25kg  
 1200W  
 450ml water tank

**Dimensions:**  
 Height - 202mm  
 Width - 310mm  
 Depth - 83mm

### SOHO ESPRESSO CUP



- Features:**
- Double walled
  - 80ml capacity
  - Easy to clean
  - Dishwasher safe up to 40°

**Specification:**  
 Glass  
 0.06kg

**Dimensions:**  
 Height - 62mm  
 Width - 65mm  
 Depth - 65mm

### FENTON MUG



- Features:**
- 300ml capacity
  - Easy to clean
  - Porcelain
  - Compatible with Corby drip tray
  - Dishwasher safe up to 40°

**Specification:**  
 Black & White  
 0.31kg

**Dimensions:**  
 Height - 109mm  
 Width - 118mm  
 Depth - 81mm



## CORBY CANTERBURY WELCOME TRAYS

Our range of Corby welcome trays features our signature drip tray, designed to eliminate the need for saucers, saving both time and money on cleaning. The Canterbury collection offers a versatile selection of trays in a variety of colours and styles, ensuring a perfect fit for any hotel room aesthetic.



### CANTERBURY CLASSIC WELCOME TRAY



- Features:**
- Accommodates all Corby Canterbury kettle
  - Integrated drip tray
  - Integrated spoon tray
  - Anti-theft
  - Easy to clean

**Specification:**  
Black  
0.35kg

**Dimensions:**  
Height - 35mm  
Width - 410mm  
Depth - 180mm

### CANTERBURY DRAWER WELCOME TRAY



- Features:**
- Accommodates all Corby Canterbury kettles
  - Built-in drawer sachet holder
  - Integrated drip tray
  - Integrated spoon tray
  - Anti-theft
  - Easy to clean

**Specification:**  
Black  
1.02kg

**Dimensions:**  
Height - 62mm  
Width - 250mm  
Depth - 210mm

## CANTERBURY COMPACT WELCOME TRAYS



- Features:**
- Accommodates all Corby Canterbury kettles
  - Built-in sachet holder
  - Integrated drip tray
  - Anti-theft
  - Solid wood
  - Rubber feet

**Specification:**  
Light Wood / Dark Wood / Black  
0.60kg

**Dimensions:**  
Height - 30mm  
Width - 230mm  
Depth - 226mm



## CORBY KENSINGTON WELCOME TRAYS

The Corby Kensington range offers space-saving solutions designed specifically for environments where worktop space is limited. Each product features our signature drip tray design for added convenience and cleanliness.



## ESSENTIALS WELCOME TRAYS

This tray was designed for hoteliers who require quick and efficient replenishment. It features a separate sachet holder that can be pre-filled before room cleaning, streamlining the restocking process and saving valuable time.



### KENSINGTON DRAWER WELCOME TRAY



### AINTREE WELCOME TRAY



**Features:**

- Accommodates the Corby Kensington 0.6L kettle
- Built-in drawer sachet holder
- Integrated drip tray
- Anti-theft
- Easy to clean

**Specification:**

Black  
1.30kg

**Dimensions:**

Height - 62mm  
Width - 245mm  
Depth - 200mm



**Features:**

- Accommodates the Corby Kensington 0.6L kettle
- Space saving design
- Integrated drip tray
- Anti-theft

**Specification:**

Black  
0.70kg

**Dimensions:**

Height - 31mm  
Width - 230mm  
Depth - 230mm



### WELCOME TRAY (LANCASTER / WT0022)



essentials

**Features:**

- Accommodates the Lancaster / KTL0004 kettle
- Anti-theft
- Integrated drip tray
- Sachet holder sold separately

**Specification:**

Black  
0.89kg

**Dimensions:**

Height - 31mm  
Width - 355mm  
Depth - 180mm



## ESSENTIALS WELCOME TRAYS

The welcome tray range includes a variety of trays in different sizes, finishes, and materials. It also offers alternative storage options to help hotels organise guest rooms more efficiently and practically. Durable and easy to use, these trays are built to meet everyday hotel needs.



### COMPACT WELCOME TRAYS (BUCKINGHAM / WT0005)

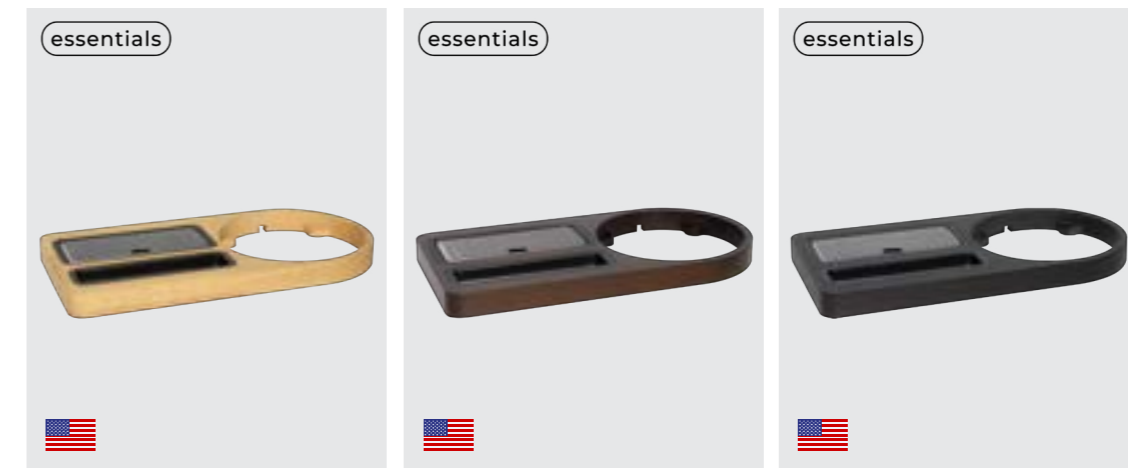

**Features:**

- Accommodates Buckingham / KTL0003 kettle
- Built-in sachet holder
- Integrated drip tray
- Solid wood / MR MDF
- Anti-theft

**Specification:**  
Light Wood / Dark Wood / Black  
0.67kg

**Dimensions:**  
Height - 30mm  
Width - 335mm  
Depth - 180mm

### STANDARD WELCOME TRAYS (BUCKINGHAM / WT0001)

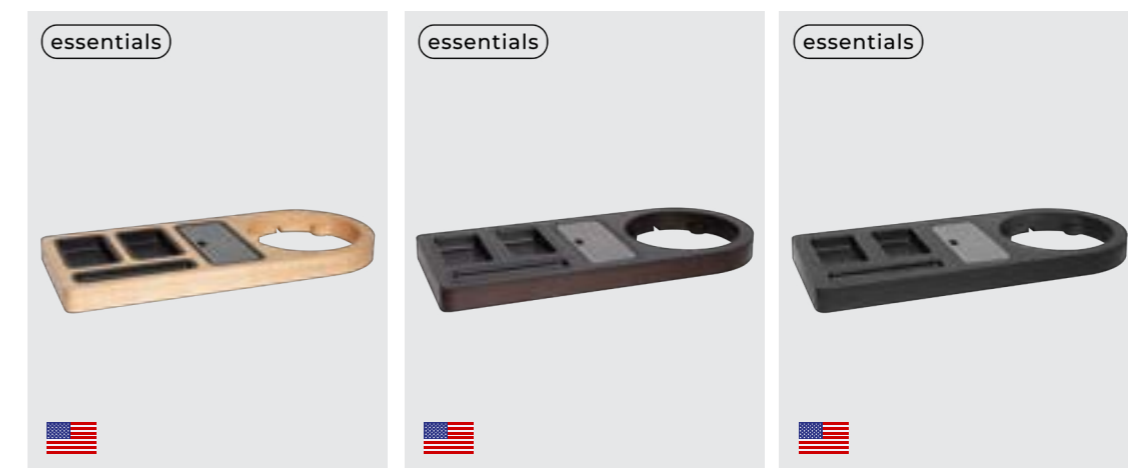

**Features:**

- Accommodates Buckingham / KTL0003 kettle
- Built-in sachet holder
- Integrated drip tray
- Solid wood / MR MDF
- Anti-theft

**Specification:**  
Light Wood / Dark Wood / Black  
1.40kg

**Dimensions:**  
Height - 35mm  
Width - 460mm  
Depth - 200mm

### WELCOME TRAY (ASCOT / WT0023)



**Features:**

- Accommodates Buckingham / KTL0003 kettle
- Durable melamine
- Hard wearing & heat resistant up to 140°C
- Integrated kettle design
- Raised sides

**Specification:**  
Black  
0.50kg

**Dimensions:**  
Height - 22mm  
Width - 345mm  
Depth - 313mm

## CORBY PU LEATHER HOSPITALITY TRAYS & SACHET HOLDERS

Our collection of PU leather hospitality trays is crafted to elevate the guest experience with a sophisticated blend of style and functionality. Meticulously designed with attention to detail, each tray offers exceptional durability while adding a touch of luxury to any setting.



HIGHLAND LARGE HOSPITALITY TRAY



HIGHLAND STANDARD HOSPITALITY TRAY



**Features:**

- Accommodates all Corby kettles, espresso machine, sachet holders & mug trays
- Luxury PU leather finish
- Durable PVC construction
- Raised sides

**Specification:**  
Black  
2.68kg

**Dimensions:**  
Height - 45mm  
Width - 457mm  
Depth - 407mm



**Features:**

- Accommodates all Corby kettles, espresso machine, sachet holders & mug trays
- Luxury PU leather finish
- Durable PVC construction
- Raised sides

**Specification:**  
Black  
2kg

**Dimensions:**  
Height - 45mm  
Width - 403mm  
Depth - 303mm



HIGHLAND SACHET HOLDER



HIGHLAND COFFEE POD & SACHET HOLDER



**Features:**

- 3 storage compartments
- Luxury PU leather finish
- Durable PVC construction

**Specification:**  
Black  
0.70kg

**Dimensions:**  
Height - 62mm  
Width - 152mm  
Depth - 152mm



**Features:**

- 4 coffee pod compartments
- 2 storage compartments
- Luxury PU leather finish
- Durable PVC construction

**Specification:**  
Black  
0.72kg

**Dimensions:**  
Height - 42mm  
Width - 217mm  
Depth - 151mm



## CORBY SOLID WOOD HOSPITALITY TRAYS & SACHET HOLDERS

Expertly crafted from sustainably sourced solid wood, this collection of hospitality trays and sachet holders showcases timeless elegance, highlighted by the rich, natural texture of the wood grain, perfectly blending classic charm with refined craftsmanship.



### BUXTON COMPACT HOSPITALITY TRAY

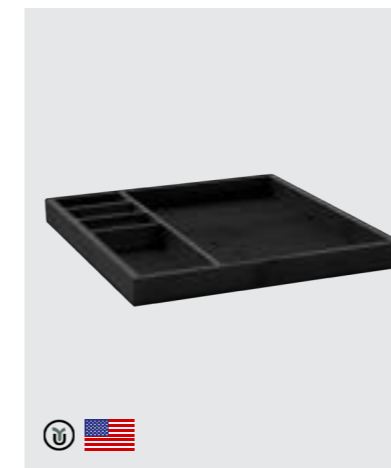

- Features:**
- Accommodates all Corby kettles
  - Made of BUSA bamboo
  - Matt wood grain finish
  - Built in sachet holders
  - Raised sides

**Specification:**  
Black  
0.63kg

**Dimensions:**  
Height - 35mm  
Width - 300mm  
Depth - 300mm



### RICHMOND COMPACT BUTLER TRAY



- Features:**
- Accommodates all Corby kettles, sachet holders and mug trays
  - Solid wood construction
  - Integrated handles
  - Raised sides

**Specification:**  
Black  
0.85kg

**Dimensions:**  
Height - 40mm  
Width - 420mm  
Depth - 320mm

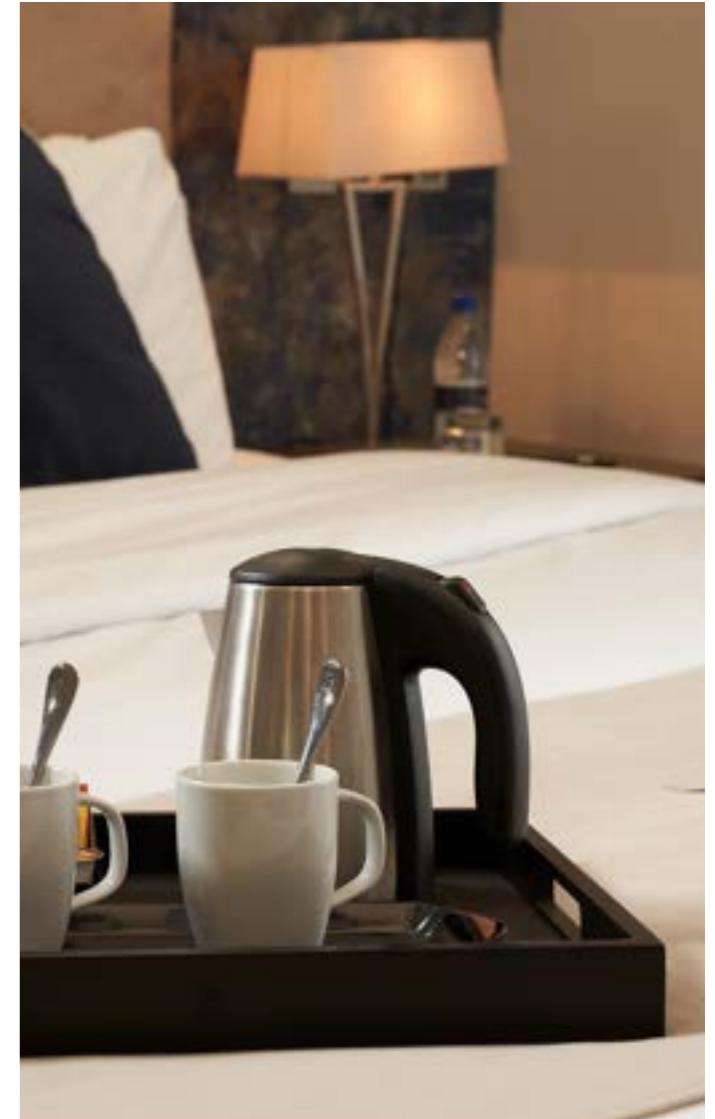

### BUXTON LARGE HOSPITALITY TRAY

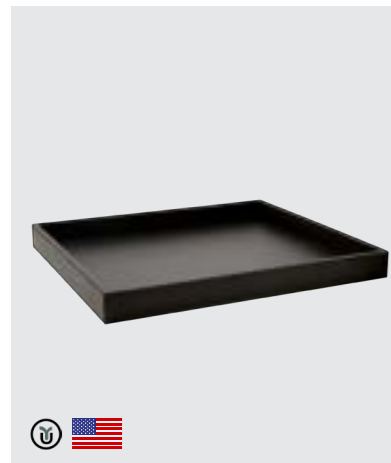

- Features:**
- Accommodates all Corby kettles, espresso machine, sachet holders and mug trays
  - Made of BUSA bamboo
  - Matt wood grain finish
  - Raised sides

**Specification:**  
Black  
1kg

**Dimensions:**  
Height - 40mm  
Width - 450mm  
Depth - 400mm



### BUXTON STANDARD HOSPITALITY TRAY

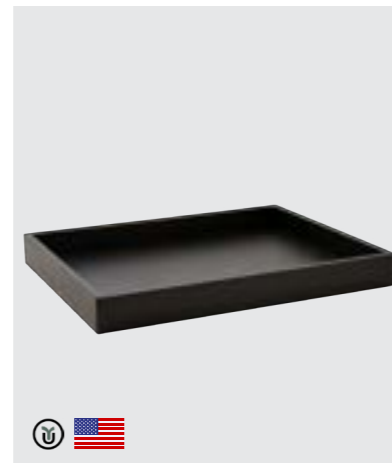

- Features:**
- Accommodates all Corby kettles, espresso machine, sachet holders and mug trays
  - Made of BUSA bamboo
  - Matt wood grain finish
  - Raised sides

**Specification:**  
Black  
0.71kg

**Dimensions:**  
Height - 40mm  
Width - 400mm  
Depth - 300mm



### BUXTON SACHET HOLDER



- Features:**
- 3 storage compartments
  - Made of BUSA bamboo
  - Matt wood grain finish

**Specification:**  
Black  
0.25kg

**Dimensions:**  
Height - 60mm  
Width - 145mm  
Depth - 145mm



### BUXTON COFFEE POD & SACHET HOLDER



- Features:**
- 4 coffee pod compartments
  - 2 storage compartments
  - Made of BUSA bamboo
  - Matt wood grain finish

**Specification:**  
Black  
0.25kg

**Dimensions:**  
Height - 40mm  
Width - 210mm  
Depth - 145mm



## PLASTIC HOSPITALITY TRAYS & SACHET HOLDERS

Available in a variety of finishes and styles, this collection can be effortlessly mixed and matched with a range of kettles and sachet holders to create a cohesive and stylish hospitality setup.



MUG TRAY (ASCOT / WT0012)

**essentials**

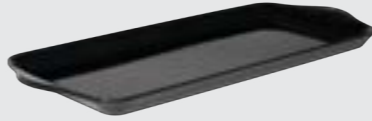

**Features:**

- Durable melamine
- Hard wearing & heat resistant up to 140°C
- Integrated handles
- Raised sides

**Specification:**

Black  
0.20kg

**Dimensions:**

Height - 20mm  
Width - 318mm  
Depth - 128mm



SACHET HOLDER (THAME / SAC0003)

**essentials**



**Features:**

- Durable melamine
- 3 storage compartments
- Easy to clean
- Hard wearing & heat resistant up to 140°C

**Specification:**

Black  
0.15kg

**Dimensions:**

Height - 45mm  
Width - 150mm  
Depth - 100mm



KENSINGTON SACHET HOLDER

**essentials**



**Features:**

- Durable nylon
- 4 storage compartments
- Easy to clean
- Hard wearing & heat resistant up to 140°C

**Specification:**

Black  
0.25kg

**Dimensions:**

Height - 38mm  
Width - 211mm  
Depth - 168mm



SACHET HOLDER (ASCOT / SAC0002)

**essentials**



**Features:**

- Durable melamine
- 3 storage compartments
- Easy to clean
- Hard wearing & heat resistant up to 140°C

**Specification:**

Black  
0.10kg

**Dimensions:**

Height - 40mm  
Width - 95mm  
Depth - 125mm



HOSPITALITY TRAY (EPSOM / WT0021)

**essentials**



**Features:**

- Accommodates all Corby kettles
- Durable gloss melamine
- Hard wearing & heat resistant up to 140°C
- Easy to clean
- Raised sides

**Specification:**

Black  
0.80kg

**Dimensions:**

Height - 26mm  
Width - 398mm  
Depth - 300mm



HOSPITALITY TRAY (WT0024)

**essentials**

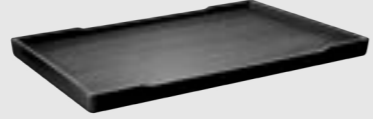

**Features:**

- Accommodates all Corby kettles
- ABS
- Wood grain effect
- Raised sides & feet

**Specification:**

Black  
0.45kg

**Dimensions:**

Height - 20mm  
Width - 398mm  
Depth - 288mm



SACHET HOLDER (MIDDLETON / SAC0001)

**essentials**



**Features:**

- ABS
- 4 storage compartments
- Rubber feet
- Easy to clean

**Specification:**

Black  
0.10kg

**Dimensions:**

Height - 55mm  
Width - 125mm  
Depth - 75mm



SACHET HOLDER (KINGSTON / SAC0004)

**essentials**



**Features:**

- Durable melamine
- Large storage compartment
- Easy to clean
- Hard wearing & heat resistant up to 140°C

**Specification:**

Black  
0.28kg

**Dimensions:**

Height - 55mm  
Width - 200mm  
Depth - 75mm





## CORBY HAIR DRYERS

Designed for guest safety, our range of stylish & functional hair dryers are available in a variety of colours, styles and specifications. Why not combine them with one of our hair dryer storage solutions? Designed for different applications, our holders and bags protect the hair dryer whilst being a stylish addition to the room's aesthetic.

# ICONIC & IONIC

As a 90 year old brand, it's important to keep up with ever changing trends & technology. Ionic technology provides a more effective way to dry all hair types. The negative ionic charge helps retain moisture, resulting in smoother, healthier looking hair with less frizz.



**Ionic Technology**

Ionic technology provides a more effective way to dry all hair types.



# YOU'RE IN CONTROL

With up to 2000W of hand-held power & heat, it's important that hair dryers are used correctly. Unfortunately, not all guests feel the same way, which is why Corby offer Trigger Activated solutions for hoteliers who would like that little extra peace of mind.



### British Designed

Our specialised range of hotel electricals & accessories is ever-evolving alongside styles & trends we see around the world. This is why we are confident we can accommodate any guest room environment.



### Trigger Activated

Specially designed for hotels, the Stratus hair dryer works on trigger activation for guest safety. The trigger activation button is easy to use and friendlier to the environment.

# SLEEK STORAGE

Corby of Windsor offer a range of storage solutions that can be used for various portable hair dryers. Most Corby hair dryers feature a specially coiled cable, which makes it much easier to store than conventional hair dryers. For example the Stratus Drawer Mounted Holder is designed to uniquely store the product so it is presented like it has never been used before.



**Bromley Hair Dryer Ring**  
Shown with Dalton 1600W hair dryer.



**Clutch Hair Dryer Holder**  
Shown with Stratus 1875W hair dryer.



**Darwen Hair Dryer Bag**  
Shown with the Bedford 2000W folding hair dryer. The Darwen hair dryer bag is made from a durable cotton and protects the hairdryer when not in use.



## Coiled Cable

Corby coiled cable hair dryers can extend from 0.8m to 2.1m in length. This makes them easy to store when compared to conventional hair dryers.



## Darwen Hair Dryer Bag

Shown with the Bedford 2000W folding hair dryer. The Darwen hair dryer bag is made from a durable cotton and protects the hairdryer when not in use.

## CORBY HAIR DRYERS

Corby offers a diverse range of hair dryers, meticulously designed with adjustable power, speed, and temperature settings. Engineered to combine style and functionality, this collection caters to the needs of both hoteliers and their guests, ensuring a seamless and comfortable experience.

### SKYE HAIR DRYER

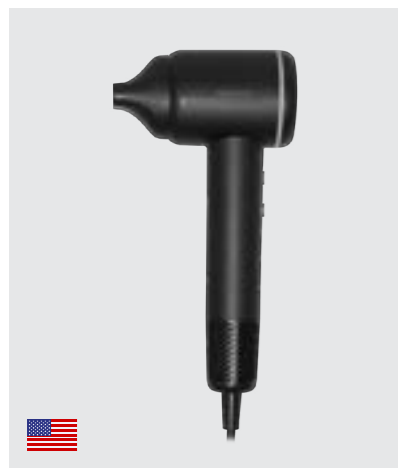

- Features:**
- Ionic technology
  - LED light heat indicator
  - 2 speed / 4 temperature settings
  - Magnetic removable filter
  - Straight cable
  - 100,000 RPM

**Specification:**  
 Black  
 1600W  
 0.50kg  
 73 dB  
 2.5m cable length

**Dimensions:**  
 Height - 280mm  
 Width - 130mm  
 Depth - 70mm



### MILTON 1875W HAIR DRYER

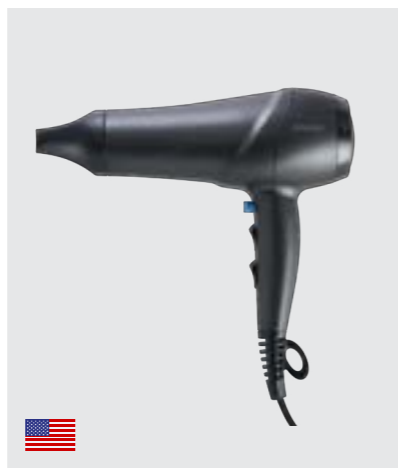

- Features:**
- Ionic technology
  - 2 speed / 3 temperature settings
  - Cool blow feature
  - Coiled cable
  - Removable filter
  - 18,000 RPM

**Specification:**  
 Black  
 1875W  
 0.60kg  
 72 dB  
 0.8 - 2.1m cable length

**Dimensions:**  
 Height - 265mm  
 Width - 270mm  
 Depth - 90mm



### KENDAL 1600W HAIR DRYER / Wall Mounted



- Features:**
- Trigger activated
  - Wall mounted
  - 2 speed / 3 temperature settings
  - Coiled cable
  - Integrated filter
  - 13,000 RPM

**Specification:**  
 White & Chrome  
 1600W  
 1.40kg  
 75 dB  
 Shaver socket: 0.05/230v & 0.1/115v

**Dimensions:**  
 Height - 260mm  
 Width - 260mm  
 Depth - 135mm

### 1200W HAIR DRYER (LINTON / RCY-67250) Wall / Drawer Mounted

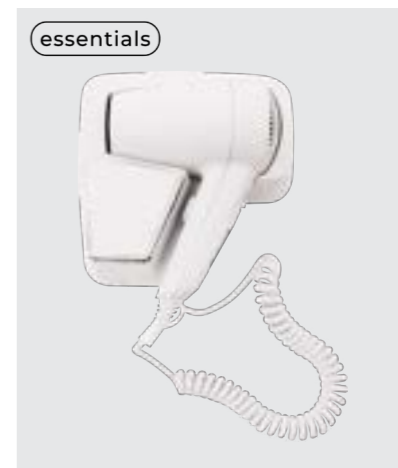

essentials

- Features:**
- Trigger activated
  - Wall mounted
  - 2 speed / 2 temperature settings
  - Coiled cable
  - Integrated filter
  - 13,000 RPM

**Specification:**  
 White & Chrome  
 1200W  
 0.75kg  
 67 dB  
 0.8 - 2.1m cable length

**Dimensions:**  
 Height - 180mm  
 Width - 200mm  
 Depth - 95mm

### 2000W HAIR DRYER (BEDFORD / CH-605)

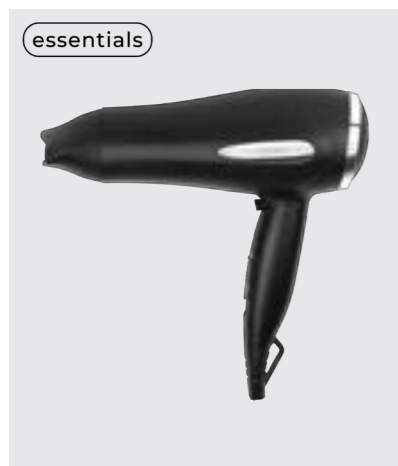

essentials

- Features:**
- Folding design
  - 2 speed / 3 temperature settings
  - Cool blow feature
  - Coiled cable
  - Removable filter
  - 18,000 RPM

**Specification:**  
 Black & Chrome  
 2000W  
 0.60kg  
 76 dB  
 0.8 - 2.1m cable length

**Dimensions:**  
 Height - 280mm (130mm folded)  
 Width - 260mm  
 Depth - 90mm

### STRATUS 1875W HAIR DRYER



- Features:**
- Ionic technology
  - Trigger activated
  - 2 speed / 3 temperature settings
  - Removable filter
  - Coiled cable
  - 18,000 RPM

**Specification:**  
 Black  
 1875W  
 0.50kg  
 78 dB  
 0.8 - 2.1m cable length

**Dimensions:**  
 Height - 240mm  
 Width - 178mm  
 Depth - 73mm

### 1200W HAIR DRYER (LINTON / 1808-10)



essentials

- Features:**
- Trigger activated
  - Ergonomic handle design
  - 2 speed / 2 temperature settings
  - Integrated filter
  - Overheat protection
  - 13,000 RPM

**Specification:**  
 White  
 1200W  
 0.40kg  
 67 dB  
 1.7m cable length

**Dimensions:**  
 Height - 219mm  
 Width - 132mm  
 Depth - 80mm

### DALTON 1600W HAIR DRYER



- Features:**
- Trigger activated
  - Ergonomic handle design
  - 2 speed / 3 temperature settings
  - Coiled cable
  - Integrated filter
  - 13,000 RPM

**Specification:**  
 Black & Chrome  
 1600W  
 0.50kg  
 75 dB  
 0.8 - 1.8m cable length

**Dimensions:**  
 Height - 260mm  
 Width - 155mm  
 Depth - 80mm



## CORBY HAIR DRYER ACCESSORIES

We offer a variety of storage solutions for our hair dryers, catering to different hotel needs and guest preferences. For a touch of elegance, our luxurious PU leather cases provide a stylish and protective option. Alternatively, our wall-mounted holders offer a practical and space-saving solution, ensuring the hair dryer is securely stored and easily accessible.

### SKYE HAIR DRYER CASE



- Features:**
- Accommodates the Skye hair dryer ONLY
  - Luxury PU leather finish
  - Velour interior finish
  - International hair dryer symbol

**Specification:**  
Black  
0.80kg

**Dimensions:**  
Height - 125mm  
Width - 350mm  
Depth - 110mm



### STRATUS HAIR DRYER HOLDER / *Drawer Mounted*

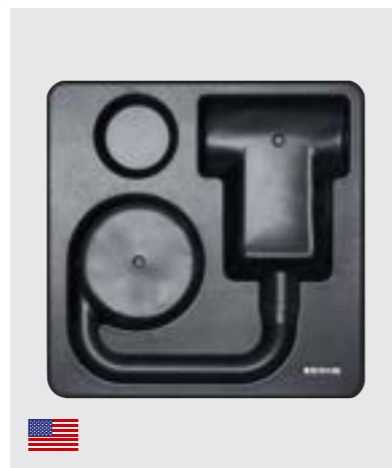

- Features:**
- Accommodates the Stratus hair dryer ONLY
  - Suitable for drawer mounting
  - Cable tidy
  - 2 fixing locations
  - Easy to clean

**Specification:**  
Black  
0.30kg

**Dimensions:**  
Height - 325mm  
Width - 325mm  
Depth - 45mm



### CLUTCH HAIR DRYER HOLDER



- Features:**
- Suitable for the Stratus, Milton, Bedford & Dalton hair dryers
  - Wall mounted
  - Concealed fixings
  - Rigid & durable construction

**Specification:**  
Black  
0.20kg

**Dimensions:**  
Height - 105mm  
Width - 120mm  
Depth - 100mm



### BROMLEY RING HAIR DRYER HOLDER

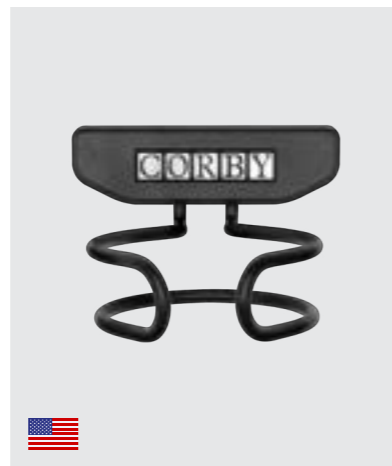

- Features:**
- Suitable for the Bedford, Milton, & Dalton hair dryers
  - Wall mounted
  - Concealed fixings
  - Rigid & durable construction

**Specification:**  
Black  
0.10kg

**Dimensions:**  
Height - 65mm  
Width - 100mm  
Depth - 90mm



### DURHAM HOLDER

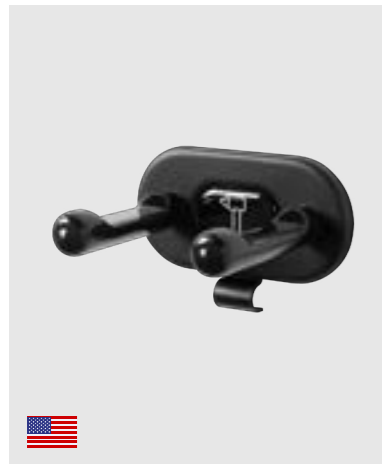

- Features:**
- Wall mounted with optional anti-theft feature
  - Durable steel construction
  - Concealed fixings with product icon
  - Anti-scratch protection
  - Compatible with all Corby hair dryers

**Specification:**  
Black  
0.29kg

**Dimensions:**  
Height - 69mm  
Width - 110mm  
Depth - 81mm



### DARWEN HAIR DRYER BAG



- Features:**
- Hair dryer symbol
  - Cotton storage bag
  - Drawstring closing
  - Machine washable
  - Compatible with all Corby hair dryers

**Specification:**  
Black  
0.06kg

**Dimensions:**  
Height - 400mm  
Width - 290mm  
Depth - 5mm





## CORBY MINIBARS

The Eton E is the world's highest rated glass door minibar on the market.\* Its innovative shelf design & use of space allow for its Silent Peltier Technology to cool it effectively, perfect for a night's stay. If your guests require a larger minibar, we offer 10L, 20L, 35L, 40L & 45L options with glass or solid lockable doors, that are sure to compliment guest room furniture. \*Checked on 20/06/23

# TAKE IT EASY

As a supplier for some of the world's finest hotels, Corby of Windsor understand that relaxation and functionality are key to any high-end hotel stay. The Minibar Collection was specifically designed to include silent technology and fit a variety of spaces, ensuring your guests receive a good night's rest every time.



### Peltier Silent Technology

Corby Minibars were designed to incorporate state of the art Peltier Silent Technology to ensure that guests have a restful stay.

# THE ART OF FLEXIBILITY

Corby minibars are designed to be adaptable to open from either the left or right side, making them suitable for most guest room layouts.



## Adjustable Cooling Technology

Corby minibars have an adjustable dial on the rear, allowing hoteliers to set the desired temperature of the contents.



## Lockable Eton Door Minibar

All the solid door Eton Minibars are lockable for additional security & peace of mind for all guests.

## Flexible Design

Eton solid door minibars can be fully integrated within furniture by fitting a 'minibar slider kit'. This creates a seamless look for minimalist styled interiors.

# EMBRACING ELEGANCE

Embrace the best of guest room hospitality with the modern elegance of the Corby of Windsor minibar collection. Our minibars have a modern & clean aesthetic which creates a high quality hospitality experience to suit a variety of guest room spaces.



**Low E Glass**  
Low - emissivity glass has a special coating designed to reflect heat back into the room, making Eton Minibars extra cold.



## CORBY MINIBARS

The Corby Minibar Collection offers a diverse selection of sizes and styles, each meticulously designed to seamlessly integrate into hotel guest rooms. From the sleek glass-door models to the spacious 45L drawer-style units, every minibar is engineered for silent operation and efficient cooling. Designed with precision, these minibars fit beautifully into a variety of room layouts, ensuring both functionality and aesthetic appeal.

### HENLEY 45L DRAWER MINIBAR | Solid Door

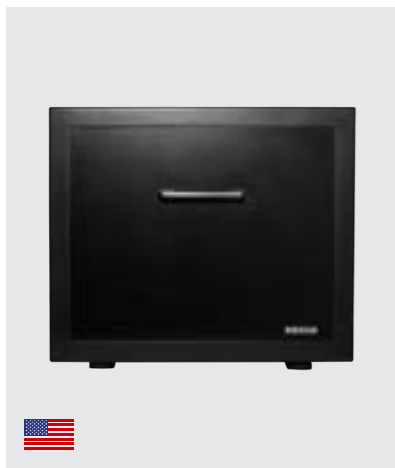

**Features:**

- Drawer open minibar
- Adjustable shelving systems
- Silent operation
- Interior LED light

**Specification:**

Black  
45L  
14kg  
58W  
R600a Refrigerant  
Insulation - Cyclopentane

**Dimensions:**

Height - 425mm  
Width - 490mm  
Depth - 460mm

**Capacity Guide:**



- 3 x Chocolate Bars
- 3 x Breakfast Bars
- 2 x 200g Chocolate Treat Bags
- 7 x Mini Cans
- 8 x 250ml Tall Cans
- 4 x 330ml Cans
- 3 x 330ml Bottles

- 1 x 1L Water Bottle or
- 1 x 750ml Wine bottle



### ETON 40L MINIBAR | Solid Door

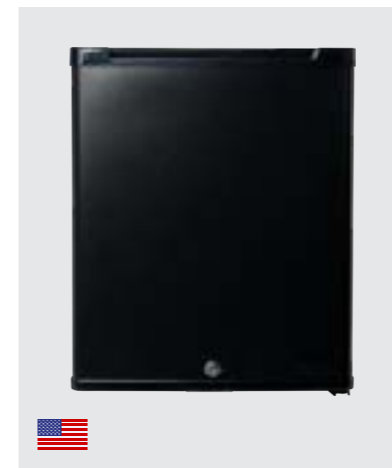

**Features:**

- Lockable door (2 keys supplied)
- Left or right opening
- Silent operation
- Interior LED light

**Specification:**

Black & White  
40L  
11.40kg  
58W  
R600a Refrigerant  
Insulation - Cyclopentane

**Dimensions:**

Height - 560mm  
Width - 400mm  
Depth - 425mm

**Capacity Guide:**

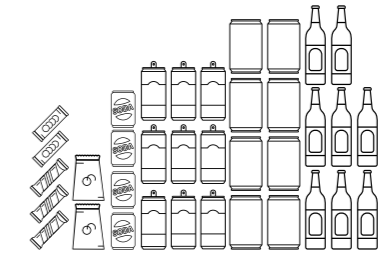

- 3 x Chocolate Bars
- 2 x Breakfast Bars
- 2 x 200g Chocolate Treat Bags
- 4 x Mini Cans
- 6 x 250ml Tall Cans
- 4 x 330ml Cans
- 7 x 330ml Bottles



### RADLEY 40L MINIBAR | Solid Door



**Features:**

- Retro design
- Left or right opening
- Silent operation
- Interior LED light

**Specification:**

Black & White  
40L  
12.30kg  
58W  
R600a Refrigerant  
Insulation - Cyclopentane

**Dimensions:**

Height - 560mm  
Width - 400mm  
Depth - 425mm

**Capacity Guide:**



- 3 x Chocolate Bars
- 2 x Breakfast Bars
- 2 x 200g Chocolate Treat Bags
- 4 x Mini Cans
- 6 x 250ml Tall Cans
- 4 x 330ml Cans
- 7 x 330ml Bottles



### ETON 40L MINIBAR | Glass Door



**Features:**

- Adjustable shelving systems
- Low E glass
- Silent operation
- Interior LED light
- Left or right opening

**Specification:**

Black & White / Black  
40L  
15.80kg  
58W  
220-240V ~ 50-60Hz  
R600a refrigerant  
Insulation - Cyclopentane

**Dimensions:**

Height - 570mm  
Width - 400mm  
Depth - 410mm

**Capacity Guide:**



- 3 x Chocolate Bars
- 2 x Breakfast Bars
- 2 x 200g Chocolate Treat Bags
- 9 x Mini Cans
- 6 x 250ml Tall Cans
- 4 x 330ml Cans
- 3 x 330ml Bottles
- 1 x 1L Water Bottle
- 1 x 750ml Wine Bottle

### RADLEY 40L MINIBAR | Solid Door



**Features:**

- Retro design
- Left or right opening
- Silent operation
- Interior LED light

**Specification:**

Cream & White  
40L  
12.30kg  
58W  
R600a Refrigerant  
Insulation - Cyclopentane

**Dimensions:**

Height - 560mm  
Width - 400mm  
Depth - 425mm

**Capacity Guide:**



- 3 x Chocolate Bars
- 2 x Breakfast Bars
- 2 x 200g Chocolate Treat Bags
- 4 x Mini Cans
- 6 x 250ml Tall Cans
- 4 x 330ml Cans
- 7 x 330ml Bottles



### ETON 35L MINIBAR | Solid Door



**Features:**

- Lockable door (2 keys supplied)
- Left or right opening
- Silent operation
- Interior LED light

**Specification:**

Black & White  
35L  
10.10kg  
58W  
R600a Refrigerant  
Insulation - Cyclopentane

**Dimensions:**

Height - 475mm  
Width - 385mm  
Depth - 455mm

**Capacity Guide:**



- 3 x Chocolate Bars
- 2 x Breakfast Bars
- 6 x Mini Cans
- 6 x 250ml Tall Cans
- 3 x 330ml Bottles
- 1 x 1L Water Bottle
- 1 x 750ml Wine Bottle



ETON 35L MINIBAR | Glass Door



- Features:**
- Adjustable shelving systems
  - Low E glass
  - Silent operation
  - Left or right opening

**Specification:**  
 Black & White / Black  
 35L  
 12.90kg  
 58W  
 R600a Refrigerant  
 Insulation - Cyclopentane

**Dimensions:**  
 Height - 485mm  
 Width - 385mm  
 Depth - 450mm

**Capacity Guide:**



- 3 x Chocolate Bars
- 2 x Breakfast Bars
- 6 x Mini Cans
- 6 x 250ml Tall Cans
- 3 x 330ml Bottles
- 1 x 1L Water Bottle
- 1 x 750ml Wine Bottle

ETON E MINIBAR | Glass Door

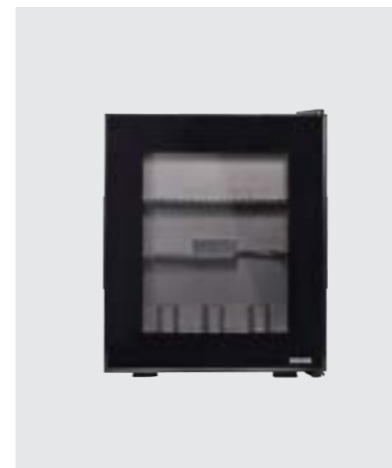

- Features:**
- B energy rating
  - Low E glass
  - Silent operation
  - Left or right opening

**Specification:**  
 Black  
 10L  
 9.96kg  
 58W  
 R600a Refrigerant  
 Insulation - Cyclopentane

**Dimensions:**  
 Height - 440mm  
 Width - 360mm  
 Depth - 280mm

**Energy Rating:**



**Capacity Guide:**

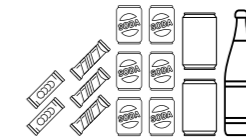

- 3 x Chocolate Bars
- 2 x Breakfast Bars
- 6 x Mini Cans
- 2 x 330ml Cans
- 1 x 1L Water Bottle

ETON 20L MINIBAR | Solid Door



- Features:**
- Lockable door (2 keys supplied)
  - Left or right opening
  - Silent operation
  - Interior LED light

**Specification:**  
 Black & White  
 20L  
 8.60kg  
 58W  
 R600a Refrigerant  
 Insulation - Cyclopentane

**Dimensions:**  
 Height - 430mm  
 Width - 360mm  
 Depth - 390mm

**Capacity Guide:**

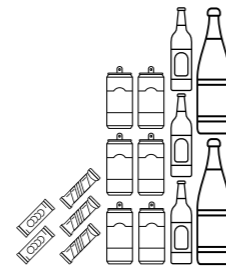

- 3 x Chocolate Bars
- 2 x Breakfast Bars
- 6 x 250ml Tall Cans
- 3 x 330ml Bottles
- 2 x 1L Water Bottle

MINIBAR SLIDER KIT



- Features:**
- Enables minibar integration into guestroom cabinets
  - Suitable for all Eton solid door minibars

**Specification:**  
 Black  
 0.32kg

**Dimensions:**  
 Height - 45mm  
 Width - 247mm  
 Depth - 9mm



ETON 20L MINIBAR | Glass Door



- Features:**
- Adjustable shelving systems
  - Low E glass
  - Silent operation
  - Left or right opening

**Specification:**  
 Black & White / Black  
 20L  
 11.70kg  
 58W  
 R600a Refrigerant  
 Insulation - Cyclopentane

**Dimensions:**  
 Height - 440mm  
 Width - 360mm  
 Depth - 385mm

**Capacity Guide:**

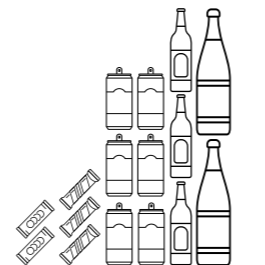

- 3 x Chocolate Bars
- 2 x Breakfast Bars
- 6 x 250ml Tall Cans
- 3 x 330ml Bottles
- 2 x 1L Water Bottle



# SAFE & SOUND

As a supplier to some of the world's finest hotels, Corby of Windsor understands that relaxation and peace of mind are integral to any hotel stay. Our Corby Safes are specifically designed to fit a variety of spaces and are constructed with heavy duty steel doors.



## CORBY SAFES

Safe & robust, our range of safes are designed to be secure & easy to use around the world. We offer different levels of security to make hotels & hotel guests feel at ease that their belongings are safe. Our CEU device allows hoteliers to set passcodes, change lighting and digitally record up to 125 passcodes, in the unlikely event of theft.



### Touch Tone

All Corby safes are digitally controlled with touch tone display panels, making it very convenient for hotel guests to store their valuables.

# PEACE OF MIND

The Corby Safes Collection is designed & engineered to be secure & easy to use around the world. We offer different levels of security to make hoteliers & hotel guests feel at ease that their belongings are safe. All safes are fitted with 18mm electronically motorised locking bolts.



## Automatic Locking System

Each safe is fitted with heavy duty motorised locking bolts that can only be opened with a pass code or a unique over-ride key (supplied).



## CEU (Computer Emergency Unit)

Our CEU device allows hoteliers to set passcodes, change lighting & digitally record up to 125 pass codes, in the unlikely event of theft.

## CORBY SAFES & CEU

The Corby Safes Collection offers a variety of sizes and styles, each meticulously designed to seamlessly integrate into hotel guest rooms. Every safe undergoes rigorous testing for functionality and quality, ensuring both security and ease of use for guests. Crafted with precision, these safes fit beautifully into diverse hotel environments, combining practicality with aesthetic appeal.

### WESTMINSTER DIGITAL 17" LAPTOP SAFE



- Features:**
- Suitable for laptops up to 17"
  - Digital braille control panel
  - Supplied with key & batteries
  - Spring assisted door
  - Compatible with CEU

**Specification:**  
 Black  
 11.80kg  
 4 x AA Batteries  
 4mm steel door  
 1.5mm steel body

**Dimensions:**  
 Height - 190mm  
 Width - 500mm  
 Depth - 380mm



### WESTMINSTER DIGITAL 15" LAPTOP SAFE



- Features:**
- Suitable for laptops up to 15"
  - Digital braille control panel
  - Supplied with key & batteries
  - Spring assisted door
  - Compatible with CEU

**Specification:**  
 Black  
 10.50kg  
 25L  
 4 x AA Batteries  
 4mm steel door  
 1.5mm steel body

**Dimensions:**  
 Height - 195mm  
 Width - 430mm  
 Depth - 370mm



### MAYFAIR DIGITAL OPEN TOP SAFE



- Features:**
- Suitable for laptops up to 15"
  - Digital braille control panel
  - Supplied with key & batteries
  - Spring assisted door
  - Compatible with CEU

**Specification:**  
 Black  
 10kg  
 11L  
 4 x AA Batteries  
 3mm steel door  
 1.5mm steel body

**Dimensions:**  
 Height - 130mm  
 Width - 400mm  
 Depth - 350mm



### CEU / Computer Emergency Unit



- Features:**
- Holds 125 passcodes
  - Cable for CEU to computer included in pack
  - Supplied with batteries
  - Compatible with the Westminster & Mayfair Safes

**Specification:**  
 Black  
 0.30kg  
 4 x AAA Batteries

**Dimensions:**  
 Height - 28mm  
 Width - 180mm  
 Depth - 78mm



### DIGITAL COMPACT SAFE (WHITEHALL / SFE0004)



essentials



- Features:**
- Suitable for laptops up to 14"
  - Supplied with key & batteries
  - Spring assisted door

**Specification:**  
 Black  
 9kg  
 18L  
 4 x AA Batteries  
 4mm steel door  
 1.5mm steel body

**Dimensions:**  
 Height - 190mm  
 Width - 420mm  
 Depth - 300mm

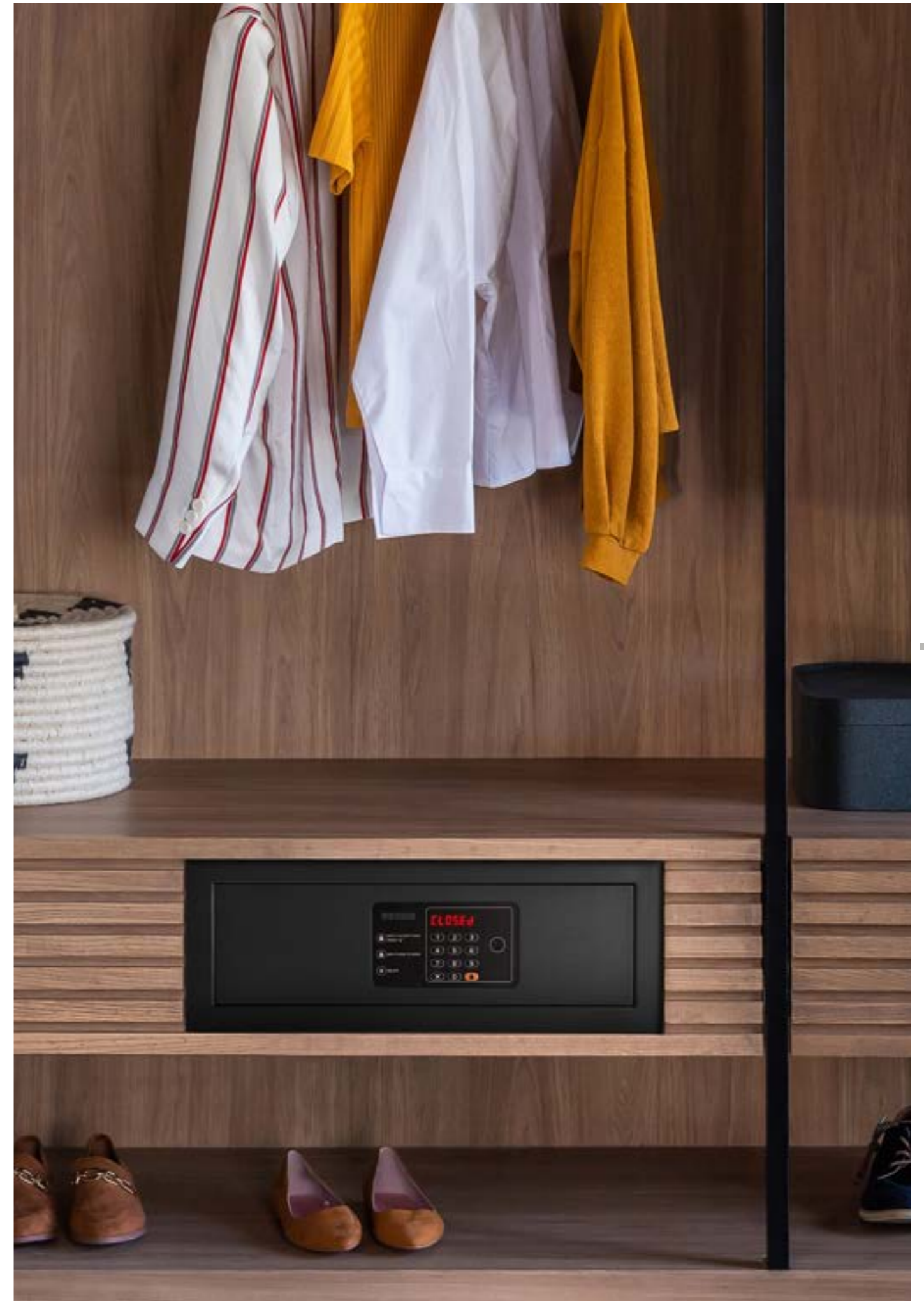



## CORBY BEDROOM COLLECTION

Our complimentary range has been specially selected to complete the room. These include tissue box holders, double layer bins, solid wood luggage racks and many more guestroom products.

# MIX & MATCH

Our solid wood range includes welcome trays, clothes hangers and luggage racks. These have been colour matched so you can be assured that the colour and finish is consistent throughout the room.



### Guest Hangers

Solid wood hangers are available in hooked or security pin options in three different colours.



Light Wood



Dark Wood



Black

### Luggage Racks

Constructed from solid wood, our collection of luggage racks have been tested to hold weight up to 50kg. The chrome inlays and durable nylon straps provide protection and enable them to be stored away.



Light Wood



Dark Wood



Black

# MAKING RECYCLING EASY

With 28 waste management solutions, hoteliers can choose how they wish to recycle. The unique Thornton recycle bin inserts can be used independently or as a set, with or without a bag liner. They feature printed international icons on top to illustrate to guests what items can be placed inside.



### Bedroom Bin Recycling

Designed to be used with our single or double layer bins, the new recycling bin inserts have been cleverly designed to be used independently or as a pair. The unique handle displays internationally recognised icons for 'general waste' and 'recycling', making it easy to understand in any guest room around the world. The handle has also been designed with 2 slots that allow a bin bag to be maneuvered around the handle so the icon isn't covered.

## CORBY BEDROOM BINS

Our curated selection of bins is thoughtfully chosen with the hotel guest in mind, seamlessly blending functionality and style. This collection now features innovative recycling solutions, including the Corby Newport Dual Recycling Bin and the Corby Thornton Bin Insert, designed to enhance waste management while complementing contemporary hotel interiors.

### HIGHLAND DUAL RECYCLING BIN

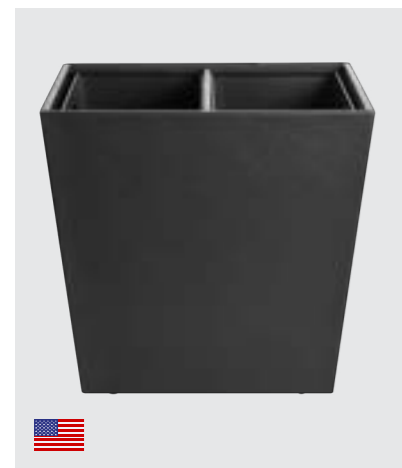

- Features:**
- Luxury PU leather finish
  - Metal inserts with handles
  - Supplied with international recycle stickers
  - Durable construction
  - Raised plastic feet

**Specification:**  
Black  
3.85kg  
6L + 6L

**Dimensions:**  
Height - 290mm  
Width - 302mm  
Depth - 173mm



### HIGHLAND 9L DOUBLE LAYER BIN



- Features:**
- Dual layer bin
  - Steel collar
  - Luxury PU leather finish
  - Durable construction
  - Rubber base

**Specification:**  
Black  
1.36kg

**Dimensions:**  
Height - 260mm  
Width - 230mm  
Depth - 230mm



### DOUBLE LAYER BIN (BIN0014)



essentials

- Features:**
- Dual layer bin
  - Steel outer layer
  - Recycled PP plastic inner
  - Polished steel collar

**Specification:**  
Black & Polished Steel  
0.84kg

**Dimensions:**  
Height - 257mm  
Width - 230mm  
Depth - 230mm



### NEWPORT DUAL RECYCLING BIN



- Features:**
- International recycling icons
  - Removable collar and inserts
  - Durable construction

**Specification:**  
Brushed Steel, Green & Black/  
Black, Green & Black  
1.96kg  
6L + 6L

**Dimensions:**  
Height - 365mm  
Width - 192mm  
Depth - 272mm



### THORNTON 9L SINGLE LAYER BIN



- Features:**
- Single layer bin
  - Durable construction
  - Rubber base

**Specification:**  
Brushed Steel / Black / White  
0.70kg

**Dimensions:**  
Height - 260mm  
Width - 230mm  
Depth - 230mm



### THORNTON 9L DOUBLE LAYER BIN



- Features:**
- Dual layer bin
  - Steel collar
  - Flame retardant
  - Durable construction
  - Rubber base

**Specification:**  
Brushed Steel / Black  
1.30kg

**Dimensions:**  
Height - 260mm  
Width - 230mm  
Depth - 230mm



### THORNTON BIN INSERT

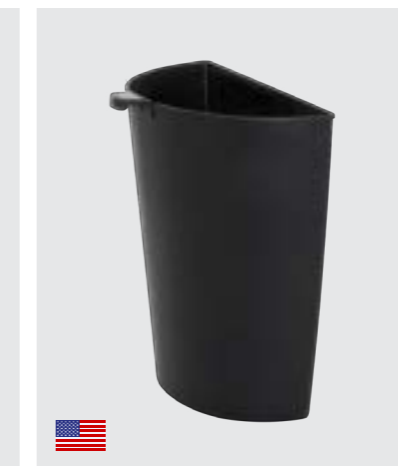

- Features:**
- Printed sorting guide
  - Suitable for Corby single or double layer bins
  - Designed to be used with or without bags
  - Easy to clean

**Specification:**  
Black (General) / Green (Recycling)  
0.20kg

**Dimensions:**  
Height - 250mm  
Width - 205mm  
Depth - 120mm



## CORBY BEDROOM HANGERS

The Guest Hanger Collection includes solid wood and metal hangers in multiple styles and colours, along with our satin hanger available in two elegant colours. These durable and stylish hangers are designed to keep your garments organised and beautifully displayed.

### CLIFFORD SUIT HANGER

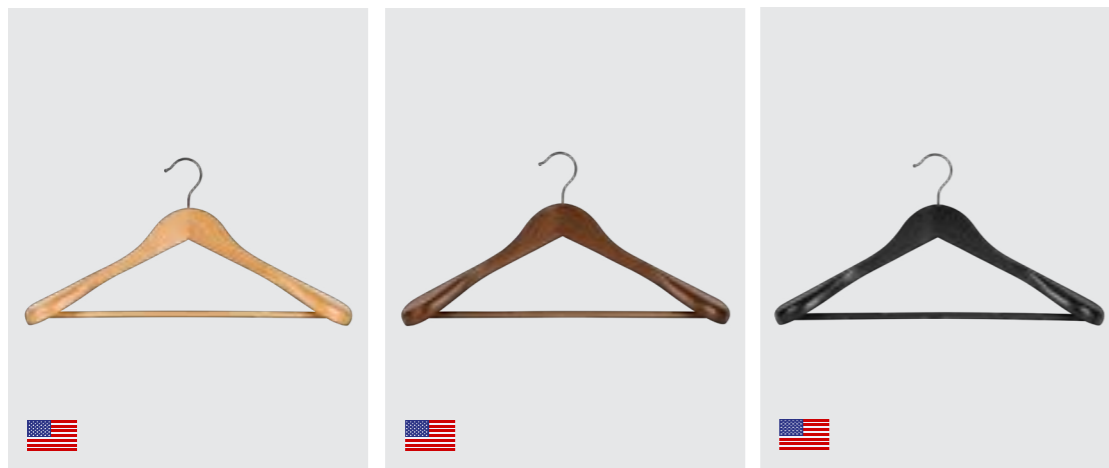

**Features:**

- Solid wood
- Standard hook
- Broad ends
- Trousers bar

**Specification:**  
Light Wood / Dark Wood / Black  
0.23kg

**Dimensions:**  
Height - 227mm  
Width - 450mm  
Depth - 60mm

### SALTAIRE SATIN GUEST HANGER



**Features:**

- Luxury satin finish
- Standard hook
- Bow detail
- Garment buttons

**Specification:**  
Black / Champagne  
0.06kg

**Dimensions:**  
Height - 145mm  
Width - 383mm  
Depth - 40mm

### BURLINGTON GUEST HANGER WITH CLIPS



**Features:**

- Solid wood
- Standard hook
- Garment clips
- Garment hooks

**Specification:**  
Light Wood / Dark Wood / Black  
0.14kg

 Pin options available

**Dimensions:**  
Height - 265mm  
Width - 445mm  
Depth - 27mm

### METAL GUEST HANGER (HGR-0007)

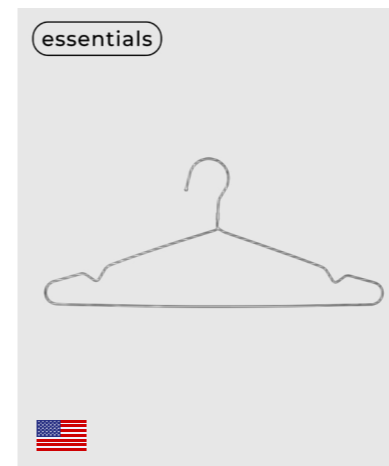

**Features:**

- Stainless steel
- Standard hook
- Garment hooks
- Trousers bar

**Specification:**  
Polished Steel  
0.06kg  
304 grade steel

**Dimensions:**  
Height - 186mm  
Width - 420mm  
Depth - 3mm

### HANGER SECURITY PIN RING



**Features:**

- Compatible with Corby security pin guest hangers
- Durable material

**Specification:**  
Silver metal  
0.01kg

**Dimensions:**  
Height - 65mm  
Width - 50mm  
Depth - 10mm

### CHELSEA GUEST HANGER



**Features:**

- Solid wood
- Standard hook
- Garment hooks
- Trousers bar

**Specification:**  
Light wood / Dark Wood / Black  
0.10kg

 Pin options available

**Dimensions:**  
Height - 215mm  
Width - 445mm  
Depth - 12mm



## CORBY LUGGAGE RACKS

Crafted from solid wood or metal, our luggage racks are engineered to support up to 50kg, ensuring durability and reliability. The sturdy nylon straps provide secure support for luggage, while the foldable design allows for easy storage, making them ideal for hotel guest rooms where space is at a premium.

### YORK LUGGAGE RACK

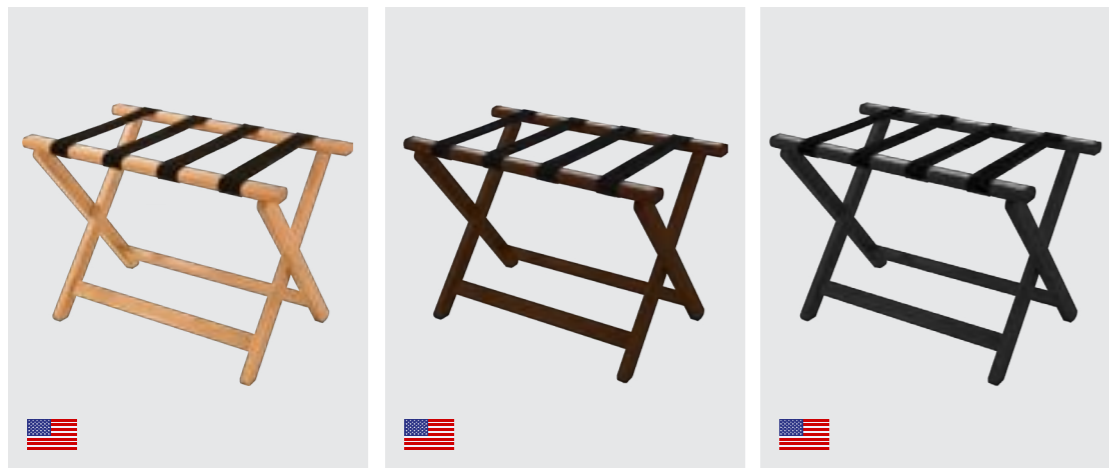

**Features:**

- Durable nylon straps
- Chrome inlays
- Solid wood construction
- Foldable & easy to store
- Holds up to 50kg

**Specification:**

Light Wood / Dark Wood / Black  
3.49kg

**Dimensions:**

(Open)	(Folded)
Height - 485mm	Height - 600mm
Width - 655mm	Width - 655mm
Depth - 385mm	Depth - 150mm



### BUXTON LUGGAGE RACK



**Features:**

- Made of BUSA bamboo
- Durable nylon straps
- Matt wood grain finish
- Designed to store in a wardrobe
- Holds up to 50KG

**Specification:**

Black  
2.80kg

**Dimensions:**

(Open)	(Folded)
Height - 460mm	Height - 585mm
Width - 450mm	Width - 450mm
Depth - 405mm	Depth - 120mm



### LUGGAGE RACK WITH BACK (ASHTON / LGR0001)



**Features:**

- Tubular steel construction
- Durable finish
- Durable nylon straps
- Foldable & easy to store
- Holds up to 50kg

**Specification:**

Polished Steel & Black / Black  
2.36kg

**Dimensions:**

(Open)	(Folded)
Height - 680mm	Height - 865mm
Width - 620mm	Width - 620mm
Depth - 515mm	Depth - 75mm

### LUGGAGE RACK WITHOUT BACK (ASHTON / LGR0002)



**Features:**

- Tubular steel construction
- Durable finish
- Durable nylon straps
- Foldable & easy to store
- Holds up to 50kg

**Specification:**

Polished Steel & Black / Black  
1.90kg

**Dimensions:**

(Open)	(Folded)
Height - 480mm	Height - 630mm
Width - 620mm	Width - 620mm
Depth - 440mm	Depth - 55mm

## CORBY BEDROOM ITEMS

As part of our extended range, we offer a selection of quality hotel products designed to enhance the guest experience. Our tissue boxes come in a variety of materials and finishes, including elegant PU leather, durable resin, and natural wood, each crafted to complement your room's décor. Additionally, our guest room electricals, such as the Regent Alarm Clock and Tower Fan, combine functionality with style, ensuring both convenience and comfort for your guests.

### BUXTON CUBE TISSUE BOX HOLDER



- Features:**
- Made of BUSA bamboo
  - Matt wood grain finish
  - Suitable for bathrooms and bedrooms

**Specification:**  
Black  
0.54kg

**Dimensions:**  
Height - 146mm  
Width - 142mm  
Depth - 142mm



### BUXTON RECTANGULAR TISSUE BOX HOLDER



- Features:**
- Made of BUSA bamboo
  - Matt wood grain finish
  - Suitable for bathrooms and bedrooms

**Specification:**  
Black  
0.54kg

**Dimensions:**  
Height - 70mm  
Width - 258mm  
Depth - 142mm



### RECTANGULAR TISSUE BOX HOLDER (DEVON / TBC0002)



essentials



essentials



- Features:**
- ABS
  - Detachable base
  - Wall or surface mounted

**Specification:**  
Chrome / Black  
0.35kg

**Dimensions:**  
Height - 60mm  
Width - 255mm  
Depth - 140mm

### HIGHLAND CUBE TISSUE BOX HOLDER



- Features:**
- Luxury PU leather finish
  - Magnetic base
  - Suitable for bathrooms and bedrooms
  - Durable PVC construction

**Specification:**  
Black  
1.20kg

**Dimensions:**  
Height - 155mm  
Width - 137mm  
Depth - 137mm



### HIGHLAND RECTANGULAR TISSUE BOX HOLDER



- Features:**
- Luxury PU leather finish
  - Magnetic base
  - Suitable for bathrooms and bedrooms
  - Durable PVC construction

**Specification:**  
Black  
1.18kg

**Dimensions:**  
Height - 74mm  
Width - 246mm  
Depth - 137mm



### CUBE TISSUE BOX HOLDER (DEVON / TBC0001)



essentials



essentials



- Features:**
- ABS
  - Detachable base
  - Easy to clean

**Specification:**  
Chrome / Black  
0.30kg

**Dimensions:**  
Height - 130mm  
Width - 135mm  
Depth - 135mm



REGENT ALARM CLOCK



- Features:**
- Wireless charging
  - 12/24 hour
  - Digital display
  - 2x USB A ports & 1x USB C port
  - 2x 5W speakers
  - Bluetooth

**Specification:**  
 Black  
 0.50kg  
 >65dB  
 1.25m cable length

**Dimensions:**  
 Height - 70mm  
 Width - 135mm  
 Depth - 125mm



TOWER FAN



- Features:**
- 70° rotation
  - Manual controls
  - Compact design
  - 3 speed settings
  - Floor standing
  - 29"

**Specification:**  
 Black  
 50W  
 2.60kg

**Dimensions:**  
 Height - 740mm  
 Width - 260mm  
 Depth - 260mm



BRIGHTON LED TORCH

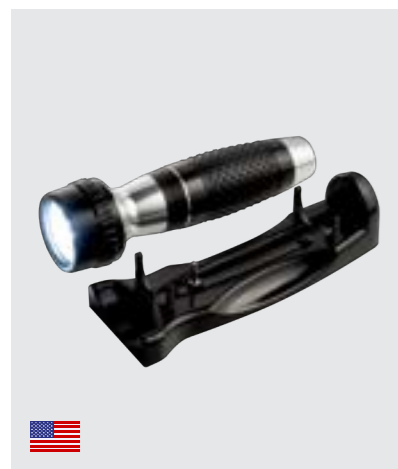

- Features:**
- Solid aluminium construction
  - Battery powered
  - Ergonomic design
  - Anti-theft
  - LED torch light
  - Wall mountable

**Specification:**  
 Black & Chrome  
 3 x AA batteries  
 0.35kg

**Dimensions:**  
 Height - 59mm  
 Width - 192mm  
 Depth - 60mm



NORTHAMPTON SHOE HORN



- Features:**
- Real wood handle
  - Hanging loop
  - Durable material

**Specification:**  
 Black  
 0.08kg

**Dimensions:**  
 Height - 382mm  
 Width - 37mm  
 Depth - 11mm



SKIPTON CLOTHES BRUSH

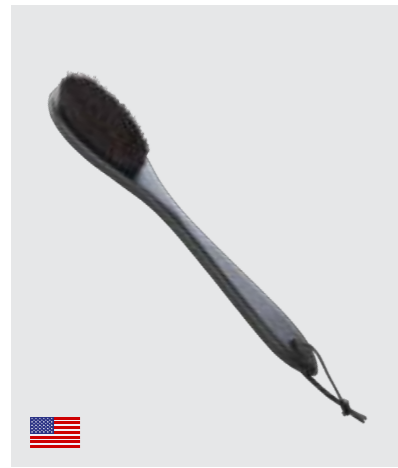

- Features:**
- 100% horse hair bristles
  - Real wood handle
  - Hanging loop
  - Durable material

**Specification:**  
 Black  
 0.14kg

**Dimensions:**  
 Height - 376mm  
 Width - 60mm  
 Depth - 36mm



FAIRFIELD LAUNDRY BAG



- Features:**
- 100% cotton
  - Adjustable drawstring
  - Machine washable
  - International laundry icon

**Specification:**  
 Natural  
 0.16kg

**Dimensions:**  
 Height - 550mm  
 Width - 450mm  
 Depth - 11mm





## CORBY BATHROOM COLLECTION

Our bathroom items include a variety of mirrors, digital scales, and essential hygiene products to enhance functionality and ensure cleanliness in the guest bathroom. Elevate your hotel bathrooms with our thoughtfully designed products, which provide both comfort and sophistication for every guest.

# RELAX & UNWIND



### Sandwell Battery-Free Scales

Our glass scales are battery-free and promote an eco-friendly lifestyle. They feature a stylish glass surface and a modern design, enhancing the aesthetic of any space. These scales provide accurate weight measurements without contributing to electronic waste. Lightweight and easy to use, they support your health while being environmentally friendly.

### Winchester Mirrors

The elegant Winchester Mirror range includes eight mirrors available in two classic colour options. Each mirror boasts a double-sided design with 5x magnification, making it ideal for precise grooming. The adjustable head allows for versatile positioning, making it a perfect choice for hoteliers seeking both style and practicality.



# CLEAN & SIMPLE

Introducing our stylish and convenient bathroom products. The Sana Toilet Brush features an easy to clean silicone head and can be wall-mounted to keep floors tidy. The Croft 3L Bathroom Pedal Bin, is perfect for hotel rooms, allowing guests to dispose of waste hygienically with its foot pedal.



## Croft 3L Pedal Bins

The Croft 3L bathroom pedal bin is an essential addition to any hotel room, designed in three classic colours to enhance the guest experience while ensuring cleanliness and convenience. These bins feature a foot-operated pedal that allows guests to dispose of waste without touching the lid, promoting a more hygienic environment.



## Sana Toilet Brush

The flexible silicone head has been designed to get to those hard to reach areas. The tiny bristles have been developed to be anti-drip and anti-clog, making cleaning the toilet less unpleasant.



## CORBY BATHROOM ITEMS

The Corby Bathroom Items Collection offers mirrors, digital scales, bathroom fixtures and essential hygiene products that enhance the guest bathroom experience. Designed for both style and functionality, it creates a clean, comfortable, and sophisticated environment for every guest.

### WINCHESTER MIRROR / FREE STANDING



- Features:**
- Double sided mirror
  - 360° rotation & tilt feature
  - Extendable arm (Chrome only)
  - 1x & 5x magnification

**Specification:**  
Chrome / Matt Black  
0.95kg

**Dimensions:**  
Height - 340 - 420mm  
Width - 230mm  
Depth - 150mm

### WINCHESTER LED MIRROR / WALL MOUNTED

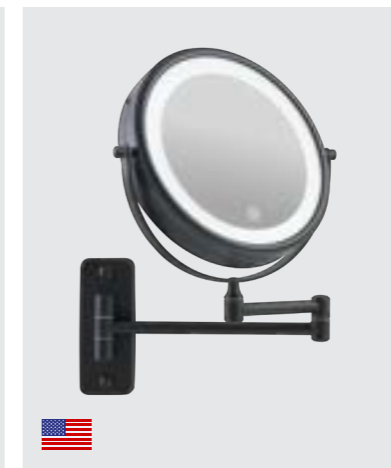

- Features:**
- LED illuminated
  - Double sided mirror
  - Auto cut-off
  - Touch screen button
  - Durable nylon hinge
  - 1x & 5x magnification
  - 360 rotation & tilt feature
  - Supplied with batteries

**Specification:**  
Chrome / Matt Black  
4 x AAA batteries  
0.95kg

**Dimensions:**  
Height - 320mm  
Width - 255 - 435mm  
Depth - 125mm

### WINCHESTER LED MIRROR / FREE STANDING



- Features:**
- LED illuminated
  - Double sided mirror
  - Auto cut-off
  - 360° rotation & tilt feature
  - Touch screen button
  - Extendable arm (Chrome only)
  - 1x & 5x magnification
  - Supplied with batteries

**Specification:**  
Chrome / Matt Black  
4 x AAA batteries  
1.10kg

**Dimensions:**  
Height - 340 - 420mm  
Width - 230mm  
Depth - 150mm

### HELMSLEY DIGITAL BATHROOM SCALES

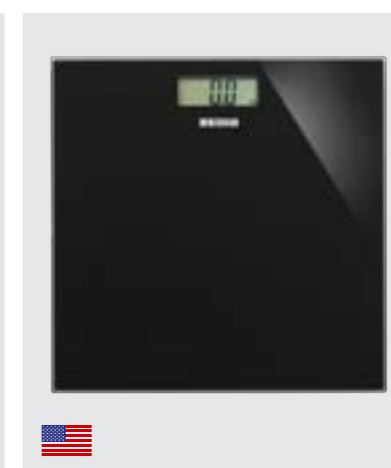
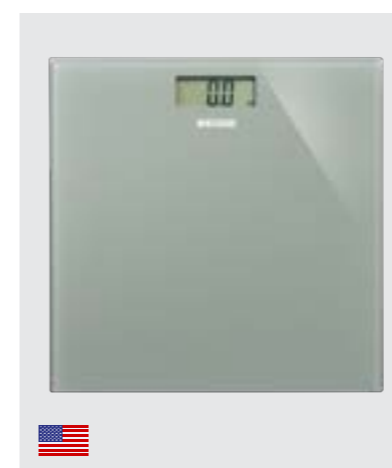

- Features:**
- LCD digital display
  - Tempered glass
  - Slimline design
  - Anti-slip rubber feet
  - Imperial & metric weight settings

**Specification:**  
Grey / Black  
1.50kg  
2 x AAA batteries  
6mm glass

**Dimensions:**  
Height - 302mm  
Width - 302mm  
Depth - 22mm

### WINCHESTER MIRROR / WALL MOUNTED



- Features:**
- Double arm mirror design
  - Double sided mirror
  - Durable nylon hinge
  - 1x & 5x magnification
  - 360 rotation & tilt feature

**Specification:**  
Chrome / Matt Black  
0.80kg

**Dimensions:**  
Height - 320mm  
Width - 255 - 435mm  
Depth - 125mm

### SANDWELL BATTERY-FREE SCALES



- Features:**
- Battery-free
  - Tempered glass
  - LCD digital display
  - Anti-slip rubber feet
  - Imperial & metric weight settings

**Specification:**  
White & Clear Glass  
1.30kg  
6mm glass

**Dimensions:**  
Height - 300mm  
Width - 310mm  
Depth - 45mm

### MARSDEN BATTERY-FREE SCALES



- Features:**
- Battery-free
  - Tempered glass
  - LCD digital display
  - Anti-slip rubber feet
  - Imperial & metric weight settings

**Specification:**  
White Glass  
1.53g  
6mm glass

**Dimensions:**  
Height - 308mm  
Width - 308mm  
Depth - 33mm



BATH MAT (DOVER / SPA0006)

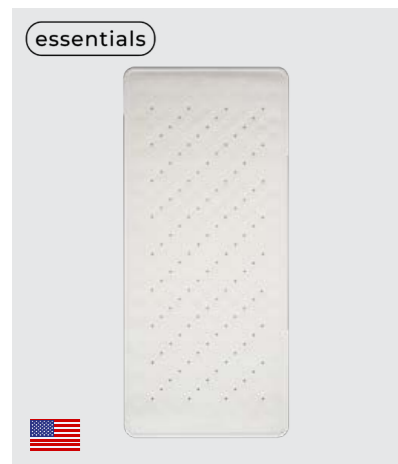

- Features:**
- Easy to clean
  - Textured rubber
  - Anti-slip suction pads

**Specification:**  
White  
0.77kg

**Dimensions:**  
Height - 740mm  
Width - 345mm  
Depth - 10mm

SELBY 5L PEDAL BIN



- Features:**
- 90° opening lid
  - Inner bin
  - Large foot pedal
  - Extra-stable base
  - Soft close

**Specification:**  
Polished Steel / Black  
0.95kg  
0.35mm thickness

**Dimensions:**  
Height - 260mm  
Width - 265mm  
Depth - 205mm



3L PEDAL BIN (CROFT / BIN0003)



- Features:**
- Compact size
  - Inner layer bin
  - Gripped foot pedal
  - Easy to clean
  - Soft close

**Specification:**  
Polished Steel / Black / White  
0.63kg  
0.26mm thickness

**Dimensions:**  
Height - 280mm  
Width - 205mm  
Depth - 255mm

TOILET BRUSH (SANA / BH0002) / FREE STANDING OR WALL MOUNTED



- Features:**
- Hygienic silicone bristles
  - Anti-drip brush head
  - Flexible brush head
  - Free standing or wall mountable
  - Slimline design

**Specification:**  
Polished Steel & Black / Black  
0.30kg

**Dimensions:**  
Height - 390mm  
Width - 115mm  
Depth - 70mm

ALTON TOILET BRUSH



- Features:**
- Durable construction
  - Nylon bristles
  - Glass interior
  - Free standing

**Specification:**  
Polished Steel / Black  
0.56kg

**Dimensions:**  
Height - 365mm  
Width - 102mm  
Depth - 102mm



## CORBY BATHROOM FIXTURES & FITTINGS

From sleek clothes hooks to elegant towel rails, our fixtures and fittings collection is crafted from premium 304 stainless steel and offered in two sophisticated finishes. Designed to seamlessly compliment our existing range of bathroom bins, mirrors, and toilet brushes, these pieces bring a cohesive, contemporary edge to any en-suite/bathroom.



### HYGIENE BAG DISPENSER (KENT / HBD0001) / WALL MOUNTED

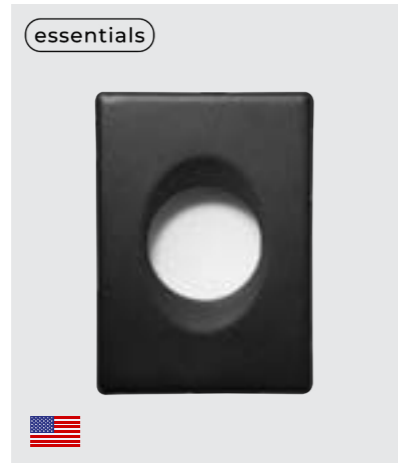
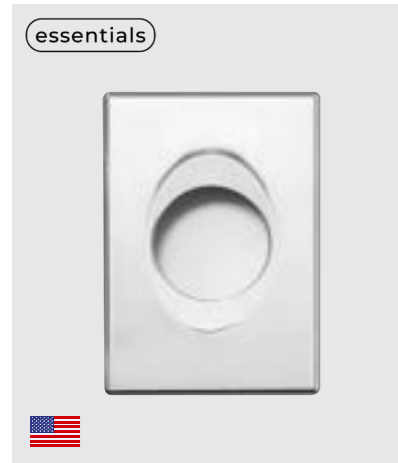

- Features:**
- Wall mountable
  - Detachable base
  - ABS construction
  - Easy to install
  - Easy to clean

**Specification:**  
 Chrome / Black  
 0.08kg

**Dimensions:**  
 Height - 138mm  
 Width - 99mm  
 Depth - 28mm

### HARROGATE TOILET ROLL HOLDER WITH COVER



- Features:**
- Wall mountable
  - Concealed fixings
  - Durable finish
  - Easy to install
  - Easy to clean

**Specification:**  
 Black / Polished Steel  
 0.32kg

**Dimensions:**  
 Height - 145mm  
 Width - 150mm  
 Depth - 90mm

### HARROGATE TOILET ROLL HOLDER

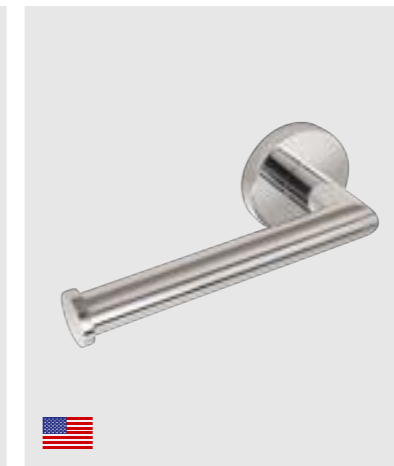
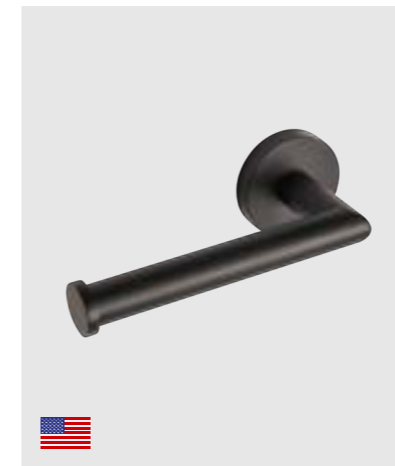

- Features:**
- Wall mountable
  - Concealed fixings
  - Durable finish
  - Easy to install
  - Easy to clean

**Specification:**  
 Black / Polished Steel  
 0.15kg

**Dimensions:**  
 Height - 55mm  
 Width - 165mm  
 Depth - 65mm





HARROGATE BATHROOM GRAB RAIL

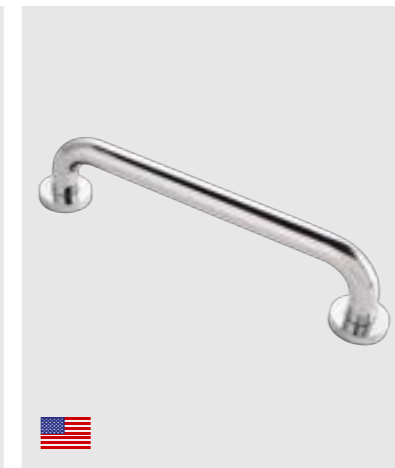
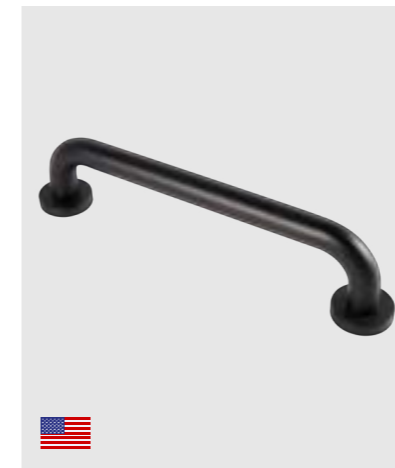

- Features:**
- Wall mountable
  - Concealed fixings
  - Durable finish
  - Easy to install
  - Easy to clean

**Specification:**  
Black / Polished Steel  
0.35kg

**Dimensions:**  
Height - mm  
Width - 352mm  
Depth - 65mm

HARROGATE SINGLE HOOK



- Features:**
- Wall mountable
  - Concealed fixings
  - Durable finish
  - Easy to install
  - Easy to clean

**Specification:**  
Black / Polished Steel  
0.09kg

**Dimensions:**  
Height - 50mm  
Width - 50mm  
Depth - 50mm

HARROGATE TOWEL RAIL



- Features:**
- Wall mountable
  - Concealed fixings
  - Durable finish
  - Easy to install
  - Easy to clean

**Specification:**  
Black / Polished Steel  
0.28kg

**Dimensions:**  
Height - 50mm  
Width - 603mm  
Depth - 70mm

HARROGATE DOUBLE HOOK

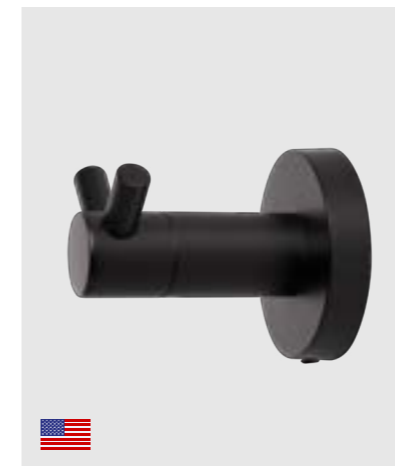

- Features:**
- Wall mountable
  - Concealed fixings
  - Durable finish
  - Easy to install
  - Easy to clean

**Specification:**  
Black / Polished Steel  
0.10kg

**Dimensions:**  
Height - 50mm  
Width - 63mm  
Depth - 50mm

# CORBY OF WINDSOR BESPOKE

Corby of Windsor Bespoke is a dedicated service crafted to deliver fully personalised solutions for leading brands and high-impact projects. Whether it's curating unique leatherette colours and textures, customising bin finishes, or re-colouring electrical appliances to complement your interior scheme, every detail is considered with precision and purpose.

As expert manufacturers of premium wood products, we also design and produce bespoke wooden components for large-scale commercial or hospitality projects. For added distinction, we offer corporate branding customisation, ensuring every product becomes a true reflection of your identity.

For more information please contact your Corby of Windsor representative.

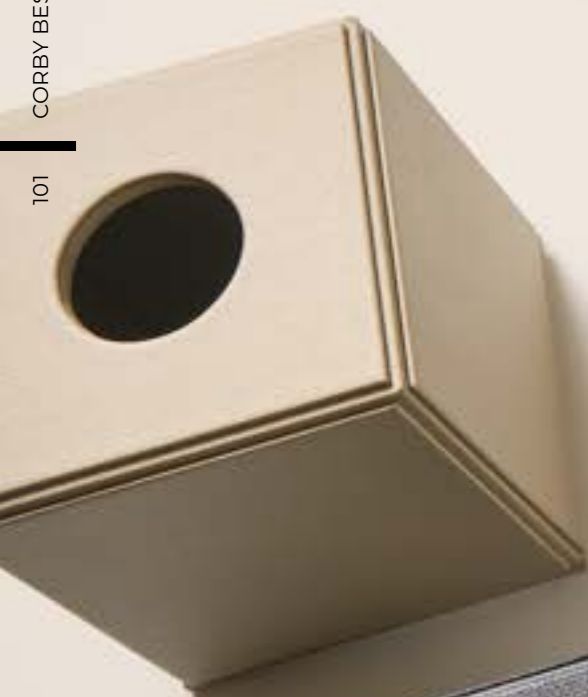

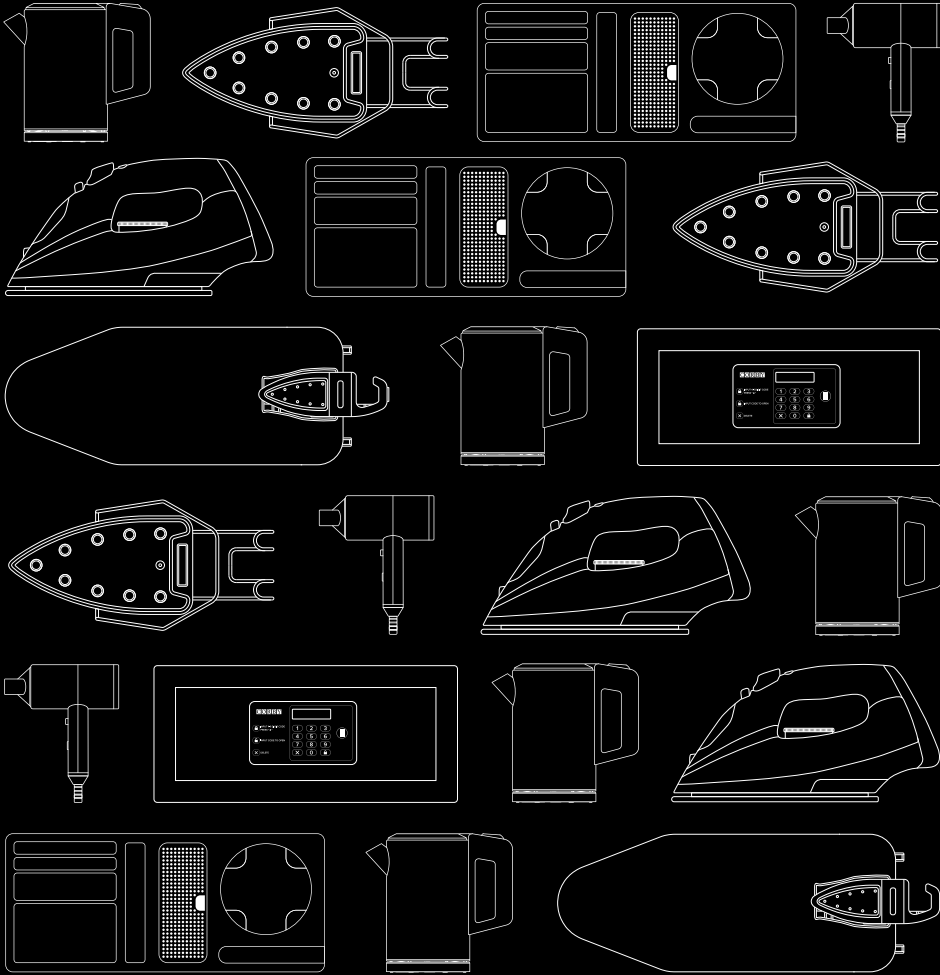

DESIGNED FOR HOTELS

**CORBY**  
of WINDSOR

[WWW.CORBYOFWINDSOR.COM](http://WWW.CORBYOFWINDSOR.COM)

2026/27 Edition